

Grizzly *Industrial, Inc.*®

MODEL G0661 10" CONTRACTOR TABLE SAW with RIVING KNIFE OWNER'S MANUAL



COPYRIGHT © OCTOBER, 2008 BY GRIZZLY INDUSTRIAL, INC.
**WARNING: NO PORTION OF THIS MANUAL MAY BE REPRODUCED IN ANY SHAPE
OR FORM WITHOUT THE WRITTEN APPROVAL OF GRIZZLY INDUSTRIAL, INC.**
#TR10845 PRINTED IN TAIWAN

 **WARNING!**

This manual provides critical safety instructions on the proper setup, operation, maintenance and service of this machine/equipment.

Failure to read, understand and follow the instructions given in this manual may result in serious personal injury, including amputation, electrocution or death.

The owner of this machine/equipment is solely responsible for its safe use. This responsibility includes but is not limited to proper installation in a safe environment, personnel training and usage authorization, proper inspection and maintenance, manual availability and comprehension, application of safety devices, blade/cutter integrity, and the usage of personal protective equipment.

The manufacturer will not be held liable for injury or property damage from negligence, improper training, machine modifications or misuse.

 **WARNING!**

Some dust created by power sanding, sawing, grinding, drilling, and other construction activities contains chemicals known to the State of California to cause cancer, birth defects or other reproductive harm. Some examples of these chemicals are:

- **Lead from lead-based paints.**
- **Crystalline silica from bricks, cement and other masonry products.**
- **Arsenic and chromium from chemically-treated lumber.**

Your risk from these exposures varies, depending on how often you do this type of work. To reduce your exposure to these chemicals: Work in a well ventilated area, and work with approved safety equipment, such as those dust masks that are specially designed to filter out microscopic particles.

Table of Contents

INTRODUCTION	2	SECTION 5: ACCESSORIES	39
Manual Accuracy	2	Aftermarket Accessories	39
Contact Info.....	2	Shop Made Safety Accessories.....	42
Functional Overview	2	SECTION 6: MAINTENANCE	43
Identification.....	3	Schedule	43
Machine Data Sheet	4	Cleaning.....	43
SECTION 1: SAFETY	7	Lubrication	44
Safety Instructions for Machinery	7	SECTION 7: SERVICE	45
Safety Instructions for Table Saws	9	Troubleshooting	45
Preventing Kickback	10	Blade Tilt Stops.....	47
Protecting Yourself From Kickback.....	10	Miter Slot to Blade Parallelism.....	48
Glossary of Terms	11	Splitter or Riving Knife Alignment	49
SECTION 2: CIRCUIT REQUIREMENTS	12	Fence Adjustments	51
110/220V Operation.....	12	Fence Scale Calibration.....	53
SECTION 3: SETUP	13	Miter Gauge Adjustments	53
Setup Safety	13	Belt Tension & Replacement	54
Items Needed for Setup.....	13	SECTION 8: WIRING	55
Unpacking	13	Wiring Safety Instructions	55
Inventory	14	Wiring Diagram	56
Hardware Recognition Chart	15	SECTION 9: PARTS	57
Clean Up.....	16	Table Saw Body Breakdown.....	57
Site Considerations.....	16	Stand Parts Breakdown	59
Assembly	17	Guard & Switch Breakdown.....	60
Dust Collection.....	21	Fence Breakdown.....	61
Test Run	22	Label Placement	62
Recommended Adjustments.....	22	WARRANTY AND RETURNS	65
SECTION 4: OPERATIONS	23		
Operation Safety	23		
Basic Controls.....	23		
Blade Selection.....	24		
Blade Installation.....	25		
Blade Guard Assembly	26		
Riving Knife.....	27		
Workpiece Inspection.....	28		
Non-Through & Through Cuts	28		
Ripping.....	29		
Crosscutting	30		
Miter Cuts.....	30		
Blade Tilt/Bevel Cuts	31		
Dado Cutting.....	31		
Rabbet Cutting.....	33		
Resawing	35		

INTRODUCTION

Manual Accuracy

We are proud to offer this manual with your new machine! We've made every effort to be exact with the instructions, specifications, drawings, and photographs of the machine we used when writing this manual. However, sometimes errors do happen and we apologize for them.

Also, owing to our policy of continuous improvement, **your machine may not exactly match the manual.** If you find this to be the case, and the difference between the manual and machine leaves you in doubt, immediately call our technical support for updates or clarification.

For your convenience, we always keep current Grizzly manuals and most updates available on our website at www.grizzly.com. Any updates to your machine will be reflected in these documents as soon as they are complete. Visit our site often to check for the latest updates!

Contact Info

We stand behind our machines. If you have any service questions or parts requests, please call or write us at the location listed below.

Grizzly Industrial, Inc.
1203 Lycoming Mall Circle
Muncy, PA 17756
Phone: (570) 546-9663
Fax: (800) 438-5901
E-Mail: techsupport@grizzly.com
Web Site: <http://www.grizzly.com>

If you have any comments regarding this manual, please write to us at the address below:

Grizzly Industrial, Inc.
c/o Technical Documentation Manager
P.O. Box 2069
Bellingham, WA 98227-2069
Email: manuals@grizzly.com

Functional Overview

The table saw is the foundation of any wood shop because it excels at making straight cuts that leave a smooth and accurate edge.

The table saw features a circular blade underneath the table that can be raised and lowered to control the depth of cut. By default, the blade is positioned 90° to the table for square cut edges, but it can be positioned anywhere between 90° and 45° for bevel cut edges.

The table saw uses a fence as the main cutting guide for the workpiece. The fence is mounted on a rail that runs alongside the table and is designed to slide freely toward and away from the blade. A scale mounted to the rail allows the operator to see how far away the fence face is from the blade in order to position the fence for the correct cutting width.

The fence is mostly used for cuts in which the workpiece can remain stable while sliding along the fence face. When a workpiece cannot slide against the fence in a stable manner, the miter gauge is used as an alternative way to guide and support the workpiece during the cut.

The miter gauge works by fitting into a specially shaped slot in the table called a "T-Slot," which allows it to slide parallel with the blade. The miter gauge body can be rotated to allow a wide range of cutting angles while its bar remains parallel to the blade.

A blade guard assembly is included with the table saw to reduce the risk of accidental injury during operation. The blade guard assembly is equipped with a clear shield so the operator can watch the workpiece during the cut. The blade guard is also equipped with a splitter and anti-kickback pawls, which respectively work to prevent kickback and stop or slow kickback if it happens.

A riving knife is also included that acts the same way as the splitter, but when the guard is removed for certain non-through cuts.



Identification

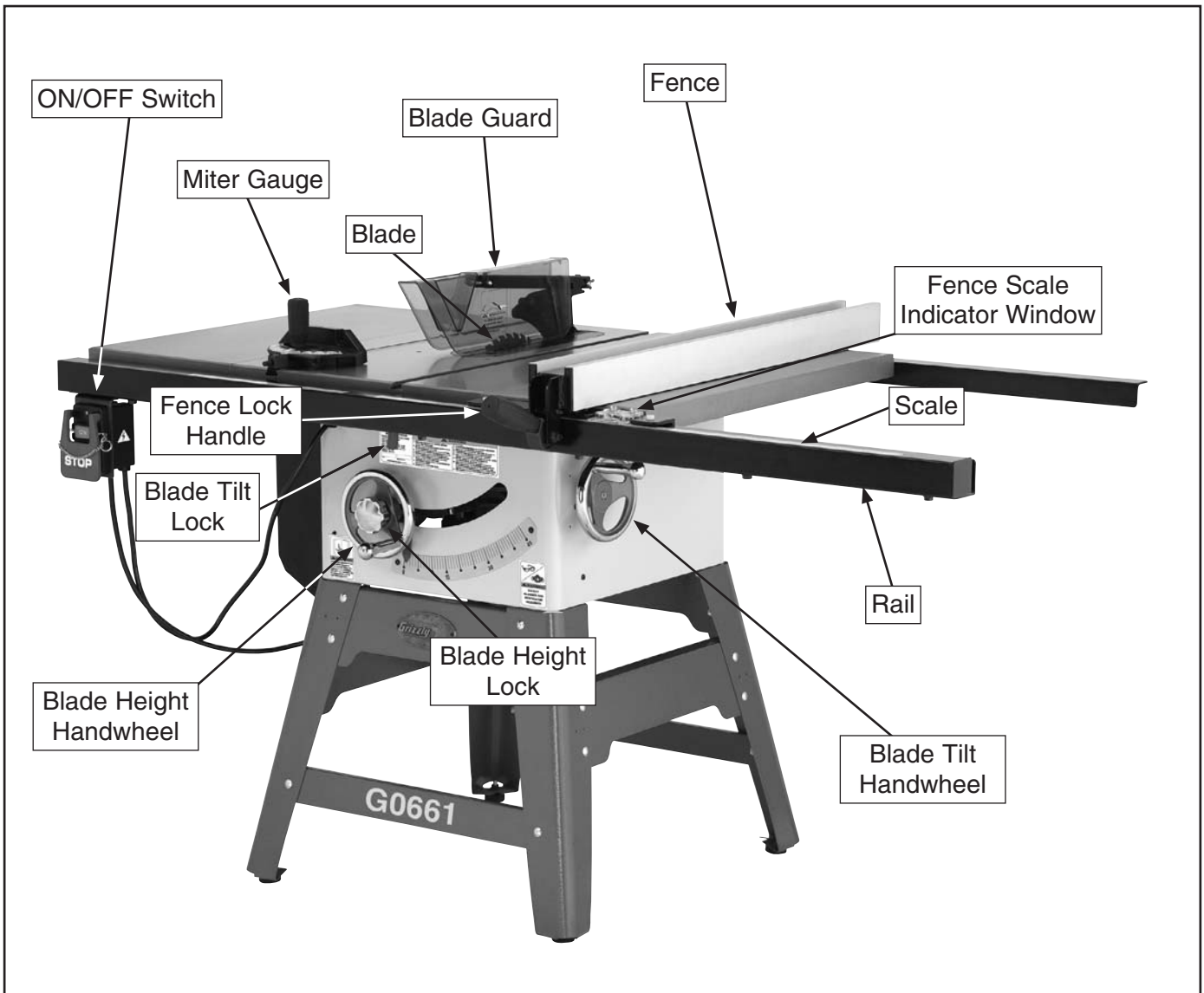

Figure 1. G0661 Identification.





MACHINE DATA SHEET

Customer Service #: (570) 546-9663 · To Order Call: (800) 523-4777 · Fax #: (800) 438-5901

MODEL G0661 10" 2 HP CONTRACTOR STYLE TABLE SAW WITH RIVING KNIFE

Product Dimensions:

Weight..... 292 lbs.
 Length/Width/Height..... 66 x 40 x 40-1/2 in.
 Foot Print (Length/Width)..... 26-1/4 x 26 in.

Shipping Dimensions:

Carton #1

Type..... Cardboard
 Content..... Machine
 Weight..... 288 lbs.
 Length/Width/Height..... 33 x 31 x 22 in.

Carton #2

Type..... Cardboard
 Content..... Fence
 Weight..... 18 lbs.
 Length/Width/Height..... 38 x 17 x 8 in.

Carton #3

Type..... Cardboard
 Content..... Rails
 Weight..... 36 lbs.
 Length/Width/Height..... 71 x 4 x 4 in.

Electrical:

Switch..... ON/OFF Push Button with Lockout Pin
 Switch Voltage..... 110/220V
 Cord Length..... 10 ft.
 Cord Gauge..... 12 guage
 Minimum Circuit Size..... 20/15 amp
 Plug Included..... Yes

Motors:

Main

Type..... TEFC Capacitor Start Induction
 Horsepower..... 2 HP
 Voltage..... 110/220V
 Prewired..... 110V
 Phase..... Single
 Amps..... 20/10A
 Speed..... 3450 RPM
 Cycle..... 60 Hz
 Number Of Speeds..... 1
 Power Transfer Belt Drive
 Bearings..... Shielded and Permanently Sealed



Main Specifications:

Blade Information

Maximum Blade Diameter.....	10 in.
Maximum Width Of Dado.....	3/4 in.
Blade Tilt.....	Left 0-45 deg.
Arbor Size.....	5/8 in.
Arbor Speed.....	4200 RPM
Arbor Bearings.....	Sealed and Permanently Lubricated
Rim Speed.....	1904 FPM

Cutting Capacities

Maximum Depth Of Cut At 90 Degrees.....	3-1/8 in.
Maximum Depth Of Cut At 45 Degrees.....	2-1/4 in.
Maximum Rip To Right Of Blade-Standard.....	36 in.
Maximum Rip To Right Of Blade-Optional.....	36 in.
Maximum Rip To Left Of Blade.....	12 in.

Table Information

Floor To Table Height.....	35-3/8 in.
Table Size Length.....	27 in.
Table Size Width.....	20 in.
Table Size Thickness.....	1-1/2 in.
Table Size With Extension Wings Length.....	27 in.
Table Size With Extension Wings Width.....	44 in.
Table Size With Extension Wings Thickness.....	1-1/2 in.
Distance Front Of Table To Center Of Blade.....	16 in.
Distance Front Of Table to Blade At Maximum Cut.....	11-1/8 in.

Fence Information

Fence Type.....	Camlock T-Shaped, Aluminum Face
Fence Size Length.....	33-1/4 in.
Fence Size Width.....	3-1/8 in.
Fence Size Height.....	2-9/16 in.
Fence Rail Type.....	Angle Iron/Square Tubing
Fence Rail Length.....	66 in.
Fence Rail Width.....	2 in.
Fence Rail Height.....	2 in.

Miter Gauge Information

Miter Gauge Slot Type.....	T-Slot
Miter Gauge Slot Size Width.....	3/4 in.
Mither Gauge Slot Size Height.....	3/8 in.

Construction

Table Construction.....	Precision Ground Cast Iron
Wings Construction.....	Precision Ground Cast Iron
Trunnions Construction.....	Cast Iron
Base Construction.....	Pre-Formed Steel
Body Assembly Construction.....	Pre-Formed Steel
Fence Assembly Construction.....	Steel with Aluminum Side Plates
Rails Construction.....	Angle Iron
Miter Guage Construction.....	Cast Iron with Steel Bar
Guard Construction.....	Steel and Clear Plastic

Other Related Information

Paint.....	Powder Coated
Number Of Dust Ports.....	1
Dust Port Size.....	2-1/2 in.
Mobile Base.....	G7314



Other Specifications:

ISO Factory ISO 9001
Country Of Origin China
Warranty 1 Year
Serial Number Location ID Label on Cabinet
Assembly Time 1 hour

Features:

- Riving Knife
- Camlock T-Shaped Fence with Aluminum Fence
- Extension Rails Available to Rip 36" Wide
- Includes Regular as well as Dado Blade Inserts
- Precision Ground Cast Iron Table with Beveled Edge
- All Machined Cast Iron Internal Structure
- Precision Ground Cast Iron Wings
- Clear Plastic Guard with Steel Splitter
- Inboard and Outboard Arbor Bearings
- Powder Coated Paint



SECTION 1: SAFETY

WARNING

For Your Own Safety, Read Instruction Manual Before Operating this Machine

The purpose of safety symbols is to attract your attention to possible hazardous conditions. This manual uses a series of symbols and signal words intended to convey the level of importance of the safety messages. The progression of symbols is described below. Remember that safety messages by themselves do not eliminate danger and are not a substitute for proper accident prevention measures.



Indicates an imminently hazardous situation which, if not avoided, **WILL** result in death or serious injury.



Indicates a potentially hazardous situation which, if not avoided, **COULD** result in death or serious injury.



Indicates a potentially hazardous situation which, if not avoided, **MAY** result in minor or moderate injury. It may also be used to alert against unsafe practices.

NOTICE

This symbol is used to alert the user to useful information about proper operation of the machine.

WARNING

Safety Instructions for Machinery

- 1. READ THE ENTIRE MANUAL BEFORE STARTING MACHINERY.** Machinery presents serious injury hazards to untrained users.
- 2. ALWAYS USE ANSI APPROVED SAFETY GLASSES WHEN OPERATING MACHINERY.** Everyday eyeglasses only have impact resistant lenses—they are NOT safety glasses.
- 3. ALWAYS WEAR A NIOSH APPROVED RESPIRATOR WHEN OPERATING MACHINERY THAT PRODUCES DUST.** Most types of dust (wood, metal, etc.) can cause severe respiratory illnesses.
- 4. ALWAYS USE HEARING PROTECTION WHEN OPERATING MACHINERY.** Machinery noise can cause permanent hearing loss.
- 5. WEAR PROPER APPAREL. DO NOT** wear loose clothing, gloves, neckties, rings, or jewelry that can catch in moving parts. Wear protective hair covering to contain long hair and wear non-slip footwear.
- 6. NEVER OPERATE MACHINERY WHEN TIRED OR UNDER THE INFLUENCE OF DRUGS OR ALCOHOL.** Be mentally alert at all times when running machinery.



WARNING

Safety Instructions for Machinery

7. **ONLY ALLOW TRAINED AND PROPERLY SUPERVISED PERSONNEL TO OPERATE MACHINERY.** Make sure operation instructions are safe and clearly understood.
8. **KEEP CHILDREN AND VISITORS AWAY.** Keep all children and visitors a safe distance from the work area.
9. **MAKE WORKSHOP CHILDPROOF.** Use padlocks, master switches, and remove start switch keys.
10. **NEVER LEAVE WHEN MACHINE IS RUNNING.** Turn power **OFF** and allow all moving parts to come to a complete stop before leaving machine unattended.
11. **DO NOT USE IN DANGEROUS ENVIRONMENTS.** DO NOT use machinery in damp, wet locations, or where any flammable or noxious fumes may exist.
12. **KEEP WORK AREA CLEAN AND WELL LIGHTED.** Clutter and dark shadows may cause accidents.
13. **USE A GROUNDED EXTENSION CORD RATED FOR THE MACHINE AMPERAGE.** Grounded cords minimize shock hazards. Undersized cords create excessive heat. Always replace damaged extension cords.
14. **ALWAYS DISCONNECT FROM POWER SOURCE BEFORE SERVICING MACHINERY.** Make sure switch is in OFF position before reconnecting.
15. **MAINTAIN MACHINERY WITH CARE.** Keep blades sharp and clean for best and safest performance. Follow instructions for lubricating and changing accessories.
16. **MAKE SURE GUARDS ARE IN PLACE AND WORK CORRECTLY BEFORE USING MACHINERY.**
17. **REMOVE ADJUSTING KEYS AND WRENCHES.** Make a habit of checking for keys and adjusting wrenches before turning machinery **ON**.
18. **CHECK FOR DAMAGED PARTS BEFORE USING MACHINERY.** Check for binding or misaligned parts, broken parts, loose bolts, and any other conditions that may impair machine operation. Repair or replace damaged parts before operation.
19. **USE RECOMMENDED ACCESSORIES.** Refer to the instruction manual for recommended accessories. Improper accessories increase risk of injury.
20. **DO NOT FORCE MACHINERY.** Work at the speed for which the machine or accessory was designed.
21. **SECURE WORKPIECE.** Use clamps or a vise to hold the workpiece when practical. A secured workpiece protects your hands and frees both hands to operate the machine.
22. **DO NOT OVERREACH.** Maintain stability and balance at all times.
23. **MANY MACHINES CAN EJECT WORKPIECES TOWARD OPERATOR.** Know and avoid conditions that cause the workpiece to "kickback."
24. **ALWAYS LOCK MOBILE BASES (IF USED) BEFORE OPERATING MACHINERY.**
25. **CERTAIN DUST MAY BE HAZARDOUS** to the respiratory systems of people and animals, especially fine dust. Be aware of the type of dust you are exposed to and always wear a respirator designed to filter that type of dust.



WARNING

Safety Instructions for Table Saws

- 1. SAFETY GUARDS.** Always use the blade guard, splitter, or riving knife on "through-sawing" operations. *The blade cuts completely through the top of the workpiece on through-sawing operations. Always use a riving knife for non-through cuts.*
- 2. KICKBACK.** Be familiar with kickback. Kickback happens when the workpiece is thrown towards the operator at a high rate of speed. *Until you have a clear understanding of kickback and how it occurs, DO NOT operate this table saw!*
- 3. REACHING OVER SAW BLADE.** Never reach behind or over the blade while the saw is running; *hands or arms will be pulled into the saw blade if kickback occurs.*
- 4. WORKPIECE CONTROL.** Make sure the workpiece is stable on the table and is supported by the rip fence or the miter gauge during cutting operations. DO NOT perform any cutting operations free-hand.
- 5. SAFETY ACCESSORIES.** Use push sticks, hold-downs, featherboards, and other devices to increase cutting safety.
- 6. OPERATOR POSITION.** Never stand or have any part of your body directly in-line with the cutting path of the saw blade. Avoid operations and hand positions where a slip could cause your hand to move into the blade.
- 7. CUT-OFF PIECES.** Turn saw **OFF** and allow blade to stop before removing workpiece cut-offs.
- 8. CROSSCUTTING OPERATIONS.** Remove the rip fence whenever using the miter gauge to crosscut a workpiece.
- 9. BLADE HEIGHT.** Always adjust the blade to the proper height above the workpiece.
- 10. WORKPIECE SUPPORT.** Provide adequate support to the rear and sides of the saw table for wide or long workpieces.
- 11. DAMAGED SAW BLADES.** Never use blades that have been dropped or otherwise damaged.
- 12. DADO AND RABBET OPERATIONS.** Dado and rabbeting operations require special attention because those operations must be performed with the blade guard removed. DO NOT attempt these operations without first reading the sections in this manual on those specific operations.
- 13. CUTTING CORRECT MATERIAL.** This machine is intended for cutting natural and man-made wood products, laminate covered wood products, and some plastics. This machine is NOT designed to cut metal, glass, stone, tile, etc.; cutting these materials with a table saw may lead to injury.
- 14. EXPERIENCING DIFFICULTIES.** If at any time you are experiencing difficulties performing the intended operation, stop using the machine! Contact our Service Department at (570) 546-9663.

WARNING

Like all machinery there is potential danger when operating this machine. Accidents are frequently caused by lack of familiarity or failure to pay attention. Use this machine with respect and caution to lessen the possibility of operator injury. If normal safety precautions are overlooked or ignored, serious personal injury may occur.

CAUTION

No list of safety guidelines can be complete. Every shop environment is different. Always consider safety first, as it applies to your individual working conditions. Use this and other machinery with caution and respect. Failure to do so could result in serious personal injury, damage to equipment, or poor work results.



Preventing Kickback

Below are tips to avoid the most common causes of kickback:

- Only cut workpieces with at least one smooth and straight edge. DO NOT cut warped, cupped or twisted wood.
- Never attempt freehand cuts. If the workpiece is not fed parallel with the blade, kickback will likely occur. Always use the rip fence or miter gauge to support the workpiece.
- Make sure the splitter or riving knife is aligned with the blade. A misaligned splitter or riving knife can cause the workpiece to catch or bind, increasing the chance of kickback. If you think that your splitter or riving knife is not aligned with the blade, check it immediately!
- Take the time to check and adjust the rip fence parallel with the blade; otherwise, the chances of kickback are extreme.
- The splitter or riving knife maintains the kerf in the workpiece, reducing the chance of kickback. Always use the riving knife for all non-through operations, unless a dado blade is installed. Always use the splitter with the blade guard for all through cuts.
- Feed cuts through to completion. Anytime you stop feeding a workpiece in the middle of a cut, the chance of kickback is greatly increased.
- Keep the blade guard installed and in good working order. Only remove it when performing non-through cuts and immediately re-install the blade guard when finished. Remember, always use the riving knife for all non-through operations, unless a dado blade is installed.
- Make multiple, shallow passes when performing a non-through cut. Making a deep non-through cut will greatly increase the chance of kickback.

WARNING

Statistics show that most common accidents among table saw users can be linked to kickback. Kickback is typically defined as the high-speed expulsion of stock from the table saw toward its operator. In addition to the danger of the operator or others in the area being struck by the flying stock, it is often the case that the operator's hands are pulled into the blade during the kickback.

Protecting Yourself From Kickback

Even if you know how to prevent kickback, it may still happen. Here are some tips to protect yourself if kickback DOES occur:

- Stand to the side of the blade during every cut. If kickback does occur, the thrown workpiece usually travels directly in front of the blade.
- Wear safety glasses or a face shield. In the event of kickback, your eyes and face are the most vulnerable part of your body.
- Never, for any reason, place your hand behind the blade. Should kickback occur, your hand will be pulled into the blade.
- Use a push stick to keep your hands farther away from the moving blade. If kickback occurs, the push stick will most likely take the damage that your hand would have received.
- Use featherboards or anti-kickback devices to prevent or slow down kickback.



Glossary of Terms

The following is a list of common definitions, terms and phrases used throughout this manual as they relate to this table saw and woodworking in general. Become familiar with these terms for assembling, adjusting or operating this machine. Your safety is **VERY** important to us at Grizzly!

Arbor: A metal shaft extending from the drive mechanism that is the mounting location for the saw blade.

Bevel Edge Cut: Tilting the arbor and saw blade to an angle between 0° and 45° to cut a beveled edge onto a workpiece. Refer to **Page 31** for more details.

Blade Guard Assembly: Metal or plastic safety device that mounts over the saw blade. Its function is to prevent the operator from coming into contact with the saw blade. Refer to **Page 26** for more details.

Crosscut: Cutting operation in which the cross-cut fence is used to cut across the shortest width of the workpiece. Refer to **Page 30** for more details.

Dado Blade: Blade or set of blades that are used to cut grooves and rabbets. Refer to **Page 40** for more details. **DO NOT use a dado blade larger than 8" in diameter on this saw!** The saw and arbor are not intended to safely use a larger dado blade.

Dado Cut: Cutting operation that uses a dado blade to cut a flat bottomed groove into the face of the workpiece. Refer to **Page 31** for more details.

Featherboard: Safety device used to keep the workpiece against the rip fence and against the table surface. Refer to **Page 42** for more details.

Kerf: The resulting cut or gap in the workpiece after the saw blade passes through during a cutting operation.

Kickback: An event in which the workpiece is propelled back towards the operator at a high rate of speed.

Non-Through Cut: A cut in which the blade does not cut through the top of the workpiece. Refer to **Page 28** for more details.

Parallel: Being an equal distance apart at every point along two given lines or planes (i.e. the rip fence face is parallel to the face of the saw blade).

Perpendicular: Lines or planes that intersect and form right angles (i.e. the blade is perpendicular to the table surface).

Push Stick: Safety device used to push the workpiece through a cutting operation. Used most often when rip cutting thin workpieces. Refer to **Page 42** for more details.

Rabbet: Cutting operation that creates an L-shaped channel along the edge of the workpiece. Refer to **Page 33** for more details.

Rip Cut: Cutting operation in which the rip fence is used to cut across the widest width of the workpiece. Refer to **Page 29** for more details.

Riving Knife: Metal plate located behind the blade. It maintains the kerf opening in the wood when performing a cutting operation. Refer to **Page 27** for more details.

Straightedge: A tool used to check the flatness, parallelism, or consistency of a surface(s).

Thin Kerf Blade: A blade with a kerf or thickness that is thinner than a standard blade. Since thin kerf blades are typically the same thickness of the splitter or riving knife—and in some cases thinner—we DO NOT recommend that they be used on this saw due to the increased risk of kickback.

Through Cut: A cut in which the blade cuts completely through the workpiece. Refer to **Page 28** for more details.



SECTION 2: CIRCUIT REQUIREMENTS

110/220V Operation

!WARNING

Serious personal injury could occur if you connect the machine to power before completing the setup process. **DO NOT** connect the machine to the power until instructed later in this manual.

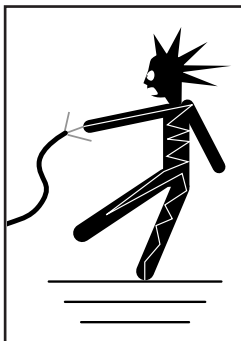

!WARNING

Electrocution or fire could result if machine is not grounded and installed in compliance with electrical codes. Compliance **MUST** be verified by a qualified electrician!

NOTICE

The Model G0661 is prewired for 110V. If you plan to operate the machine at 220V, the motor must be rewired (see Page 56) and a 220V plug must be installed.

Full Load Amperage Draw

Amp Draw at 110V (prewired).....20 Amps
Amp Draw at 220V 10 Amps

Power Supply Circuit Requirements

You **MUST** connect your machine to a grounded circuit that is rated for the amperage given below. Never replace a circuit breaker on an existing circuit with one of higher amperage without consulting a qualified electrician to ensure compliance with wiring codes. **If you are unsure about the wiring codes in your area or you plan to connect your machine to a shared circuit, consult a qualified electrician.**

Minimum Circuit Size for 110V.....20 Amps
Minimum Circuit Size for 220V..... 15 Amps

220V Power Connection Device

The type of plug required to connect your machine to power depends on the type of service you currently have or plan to install. A 110V plug is included with this machine. If you plan to use your machine at 220V, we recommend using the plug type shown in **Figure 2**.

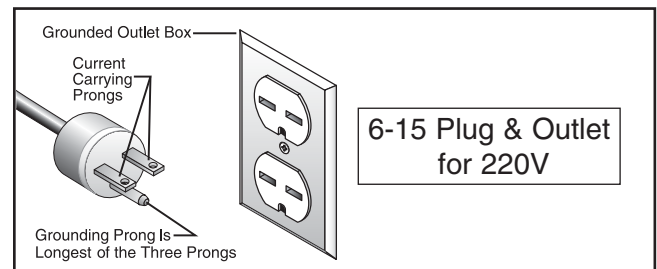

Figure 2. Recommended plug types.

Extension Cords

Using extension cords may reduce the life of the motor. Instead, place the machine near a power source. If you must use an extension cord:

- For 110V, use at least a 12 gauge cord that does not exceed 50 feet in length.
- For 220V, use at least a 14 gauge cord that does not exceed 50 feet in length.
- The extension cord must have a ground wire and plug pin.



SECTION 3: SETUP

Setup Safety

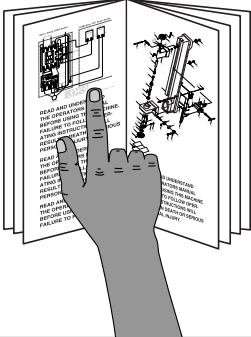

!WARNING
This machine presents serious injury hazards to untrained users. Read through this entire manual to become familiar with the controls and operations before starting the machine!



!WARNING
Wear safety glasses during the entire setup process!



!WARNING
This machine and its components are very heavy. Get lifting help or use power lifting equipment such as a forklift to move heavy items.

Items Needed for Setup

The following items are needed to complete the setup process, but are not included with your machine:

Description	Qty
• Safety Glasses (for each person)	1
• Degreaser or Solvent for Cleaning.....	Varies
• Throw-Away Rags for Cleaning	Varies
• Straightedge	1
• Level.....	1
• Wrench or Socket Wrench 10mm	1
• Wrench or Socket Wrench 12mm	1
• Wrench or Socket Wrench 14mm	1
• Phillips Head Screwdriver #2	1
• Strong Helpers for Lifting	2

Unpacking

Your machine was carefully packaged for safe transportation. Remove the packaging materials from around your machine and inspect it. If you discover the machine is damaged, *please immediately call Customer Service at (570) 546-9663 for advice.*

Save the containers and all packing materials for possible inspection by the carrier or its agent. *Otherwise, filing a freight claim can be difficult.*

When you are completely satisfied with the condition of your shipment, inventory the contents.



Inventory

The following is a description of the main components shipped with your machine. Lay the components out to inventory them.

Note: *If you can't find an item on this list, check the mounting location on the machine or examine the packaging materials carefully. Occasionally we pre-install certain components for shipping.*

Box Contents (Figures 3–5):	Qty
A. Table Saw Unit (not shown).....	1
B. Right Stand Legs.....	2
C. Left Stand Legs.....	2
D. Extension Wings.....	2
E. Feet.....	4
F. Upper Stand Braces.....	2
G. Side Stand Braces.....	2
H. Lower Stand Braces.....	2
I. Motor Cover.....	1
J. Splitter/Blade Guard Assembly.....	1
K. Table Tilt Handwheel.....	1
L. Handle.....	1
M. Dado Table Insert.....	1
N. Miter Gauge Assembly.....	1
O. Arbor Wrenches.....	2
P. Wrench 11/13mm.....	1
Q. Hex Wrench 2.5, 5, 6mm.....	1 Each
R. Metal Shims.....	3
S. Front Rail Rectangular Tube.....	1
T. Front Rail.....	1
U. Rear Rail.....	1
V. Fence Assembly.....	1
W. Fence Lock Knob.....	1

Hardware (Not Shown):	Qty
Key 4 x 4 x 10mm (Handwheel).....	1
Set Screw M5-.8 x 6 (Handwheel).....	1
Hex Bolts M8-1.25 x 20 (Wings).....	8
Lock Washers 8mm (Wings).....	8
Carriage Bolts M8-1.25 x 12 (Stand).....	28
Flat Washers 8mm (Stand/Feet).....	36
Hex Nuts M8-1.25 (Stand/Feet).....	36
Hex Bolts M6-1 x 12 (Switch).....	2
Flat Head Screws M8-1.25 x 25 (Fence).....	6
Lock Washers 8mm (Fence).....	6
Hex Nuts M8-1.25 (Fence).....	6
Flange Cap Screws M8-1.25 x 25 (Fence).....	6
Hex Nuts M8-1.25 (Fence).....	6
Flange Bolts M8-1.25 x 10 (Fence).....	6
Flat Washers 8mm (Fence).....	6

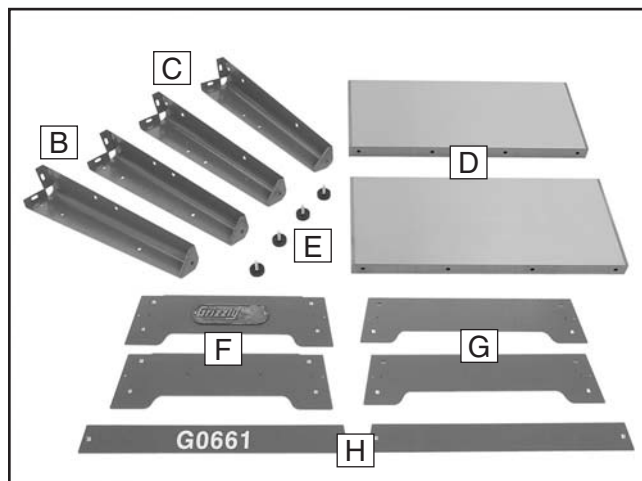

Figure 3. Inventory contents 1.

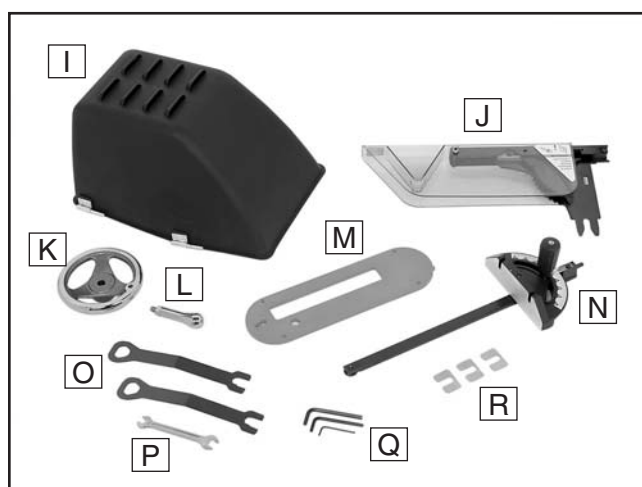

Figure 4. Inventory contents 2.

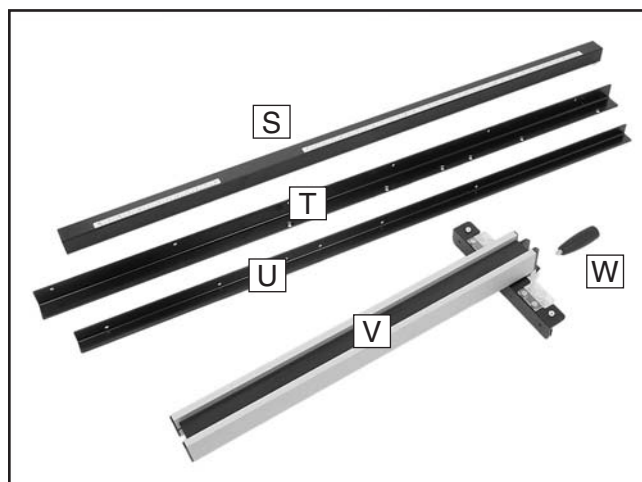

Figure 5. Fence inventory contents.



Hardware Recognition Chart

USE THIS CHART TO MATCH UP HARDWARE DURING THE ASSEMBLY PROCESS.

MEASURE BOLT DIAMETER BY PLACING INSIDE CIRCLE

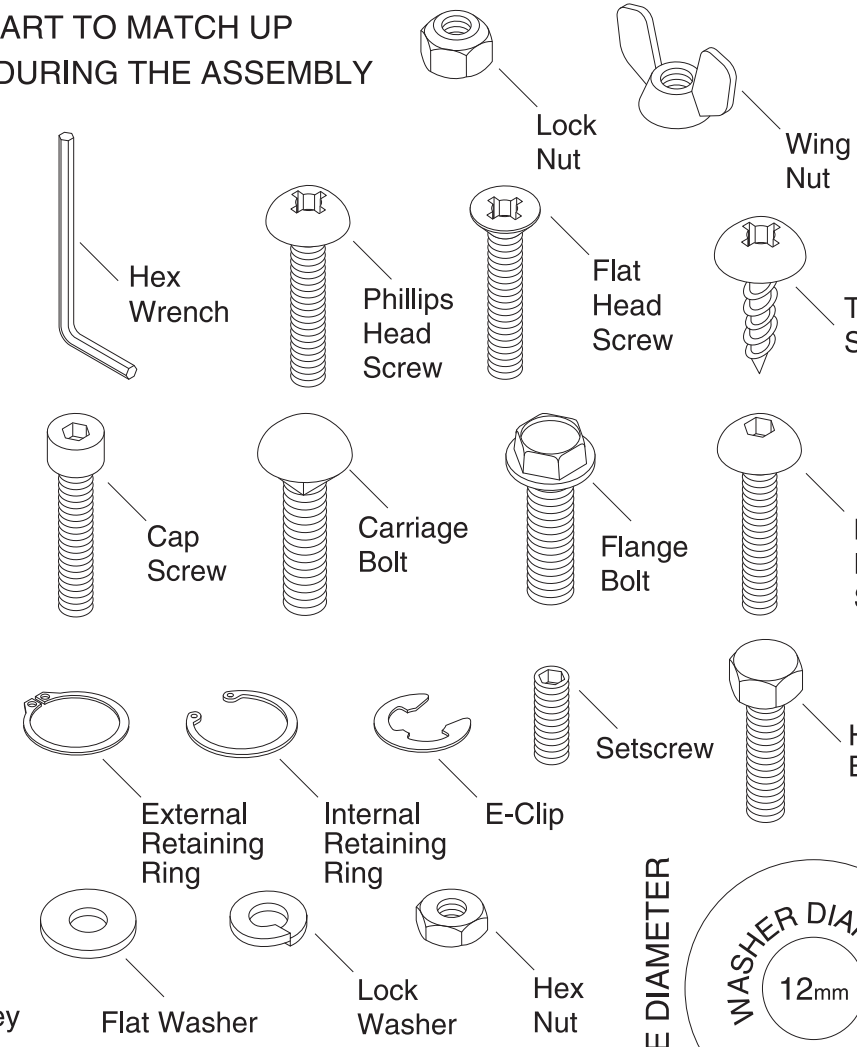
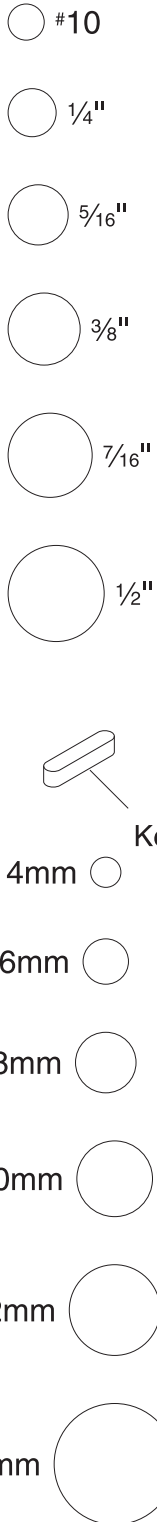



WASHERS ARE MEASURED BY THE INSIDE DIAMETER



Clean Up

The unpainted surfaces are coated with a waxy oil to prevent corrosion during shipment. Remove this protective coating with a solvent cleaner or degreaser, such as shown in **Figure 6**. For thorough cleaning, some parts must be removed. **For optimum performance, clean all moving parts or sliding contact surfaces.** Avoid chlorine-based solvents, such as acetone or brake parts cleaner that may damage painted surfaces. Always follow the manufacturer's instructions when using any type of cleaning product.

	<p>! WARNING Gasoline and petroleum products have low flash points and can explode or cause fire if used to clean machinery. DO NOT use these products to clean the machinery.</p>
-----------------------------------------------------------------------------------	------------------------------------------------------------------------------------------------------------------------------------------------------------------------------------------------------

	<p>! CAUTION Many cleaning solvents are toxic if inhaled. Minimize your risk by only using these products in a well ventilated area.</p>
-------------------------------------------------------------------------------------	-----------------------------------------------------------------------------------------------------------------------------------------------------

G2544—Solvent Cleaner & Degreaser
H9692—Orange Power Degreaser
 Great products for removing shipping grease.

	<p>Call 1-800-523-4777 To Order</p>	
-------------------------------------------------------------------------------------	--------------------------------------------------------------	-------------------------------------------------------------------------------------

Figure 6. Cleaner/degreasers available from Grizzly.

Site Considerations

Floor Load

Refer to the **Machine Data Sheet** for the weight and footprint specifications of your machine. Some residential floors may require additional reinforcement to support both the machine and operator.

Placement Location

Consider existing and anticipated needs, size of material to be processed through each machine, and space for auxiliary stands, work tables or other machinery when establishing a location for your new machine. See **Figure 7** for the minimum working clearances.

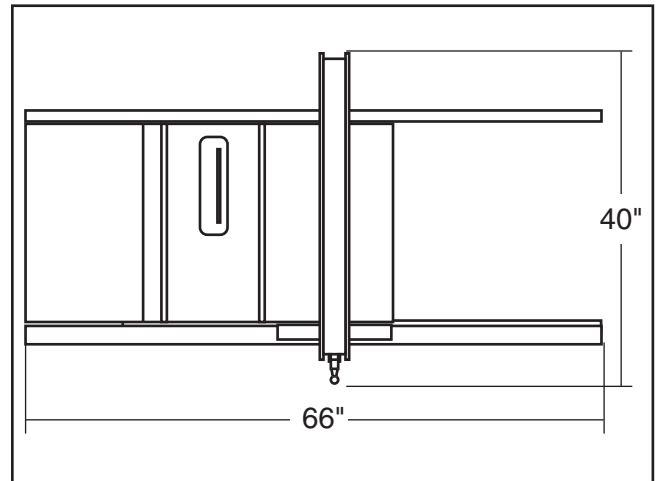
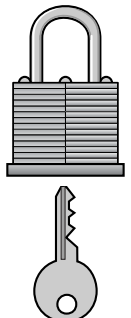

Figure 7. Minimum working clearances.

	<p>! CAUTION Children and visitors may be seriously injured if unsupervised around this machine. Lock entrances to the shop or disable start switch or power connection to prevent unsupervised use.</p>
--------------------------------------------------------------------------------------	---------------------------------------------------------------------------------------------------------------------------------------------------------------------------------------------------------------------



Assembly

To assemble the table saw:

1. Attach the upper stand braces to the top holes of the left and right legs with eight M8-1.25 x 12 carriage bolts, 8mm flat washers, and M8-1.25 hex nuts (**Figure 8**). Just hand tighten the fasteners for this step.

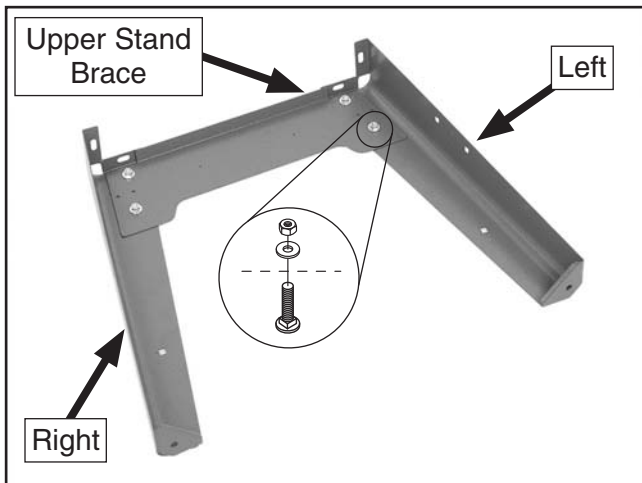

Figure 8. Upper stand brace secured to legs.

2. Attach the lower stand braces to the leg assemblies from **Step 1** with four M8-1.25 x 12 carriage bolts, 8mm flat washers, and M8-1.25 hex nuts (**Figure 9**). Just hand tighten the fasteners for this step.

Note: Make sure the upper stand brace with the Grizzly logo is on the same side as the lower stand brace with the G0661 label.

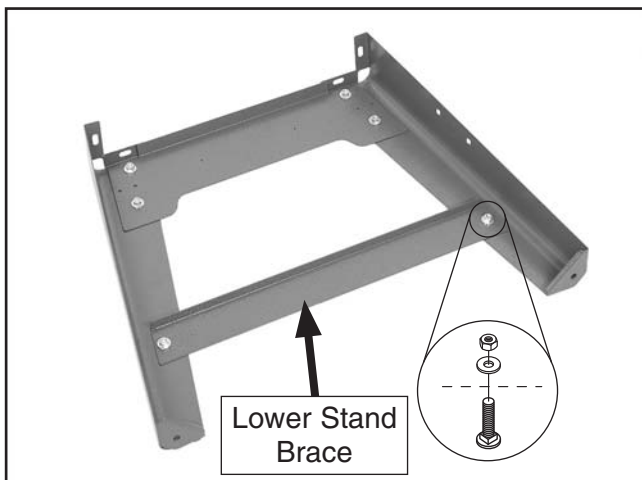

Figure 9. Lower stand brace secured to legs.

3. Attach both leg assemblies together with the remaining side stand braces and eight M8-1.25 x 12 carriage bolts, 8mm flat washers, and M8-1.25 hex nuts (**Figure 10**). Just hand tighten the fasteners for this step.

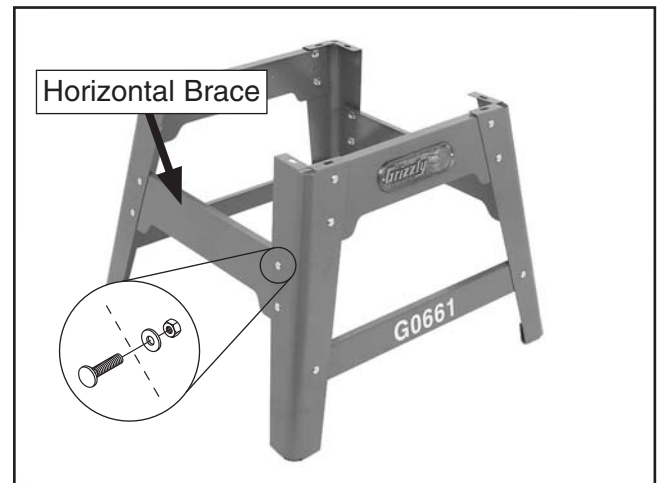

Figure 10. Stand assembly completed.

4. Use M8-1.25 hex nuts and 8mm flat washers to attach each foot to the bottom of the stand, as shown in **Figure 11**.

Note: Adjust the hex nuts to approximately the same position on the threaded shaft of the feet during this step to make leveling easier during a later step.

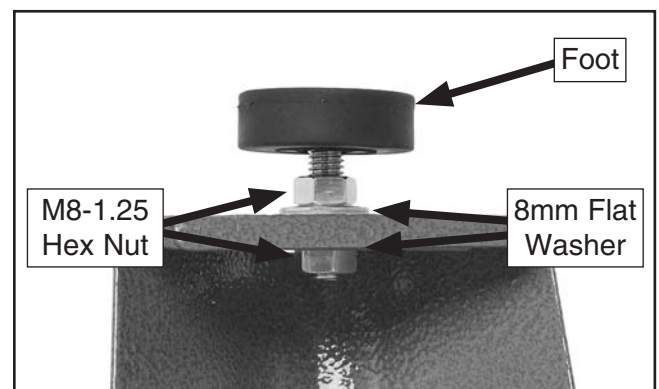

Figure 11. Foot installed with hex nuts and flat washers.



5. Make sure the blade is lowered all the way into the saw by turning the front handwheel. Place the saw upside down on a piece of cardboard, then place the stand assembly on the saw so the Grizzly logo faces the same direction as the front of the saw (**Figure 12**).



Figure 12. Stand assembly positioned on saw.

6. Attach the stand to the saw with eight M8-1.25 x 12 carriage bolts, 8mm flat washers, and M8-1.25 hex nuts. Tighten these fasteners with a wrench.
7. Get help from a couple of people to turn the saw upright so it rests on the feet. **DO NOT ATTEMPT THIS BY YOURSELF!**
8. Place a level on the table and level the saw from side-to-side and front-to-back, then fully tighten all the stand fasteners with a 12mm wrench (or socket).
9. Place the included 4 x 4 x 10 key in the handwheel shaft, and slide the handwheel onto the shaft on the side of the table saw. Use the included 2.5mm hex wrench to tighten the M5-.8 x 20 setscrew in the side of the handwheel hub (**Figure 13**) until secure.



Figure 13. Handwheel installed on side of saw.

10. Inspect the extension wing and main table mating surfaces for burrs or foreign material that may inhibit assembly.

The mating edges of the wings and the table must be clean, smooth, and flat. Use a wire brush or file if necessary to clean up the edges. This step will ensure that the wings mount properly to the main table.

11. Using a helper to hold the wings in place, attach each extension wing to the main table with four M8-1.25 x 20 hex bolts and 8mm lock washers (**Figure 14**).

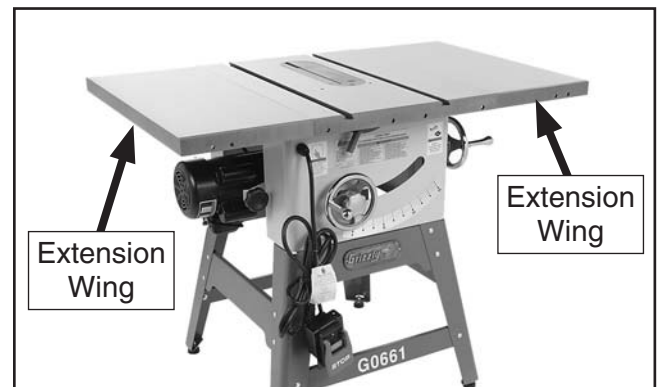

Figure 14. Extension wings installed on saw.

12. Place the straightedge across the extension wings and main table to make sure that the combined table surface is flat.

—If the combined table surface is flat, skip to the next step.

—If the outside end of the extension wing tilts down, use a strip of masking tape along the bottom edge of the main table to shim the extension wing up (**Figure 15**).

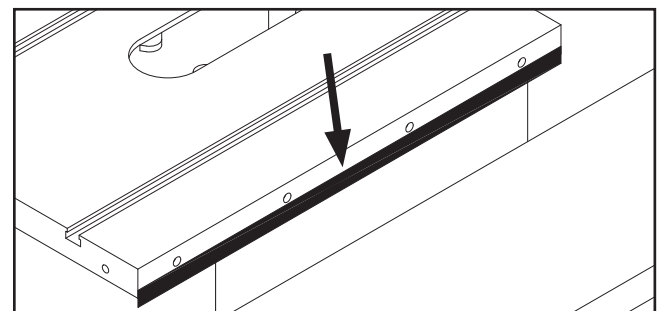

Figure 15. Masking tape location for tilting the extension table up.



- If the outside end of the extension wing tilts up, use a strip of masking tape along the top edge of the main table to shim the extension wing down (**Figure 16**).

Note: After reinstalling wings, remove all excess masking tape with a razor blade.

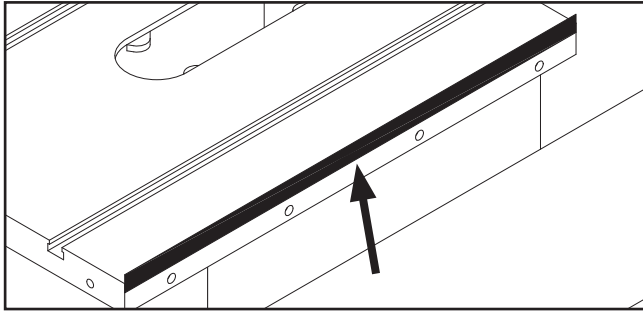

Figure 16. Masking tape location for adjusting the extension wing down.

13. Install the front rail with six M8-1.25 x 25 flat head screws, 8mm lock washers, and M8-1.25 hex nuts (**Figure 17**).

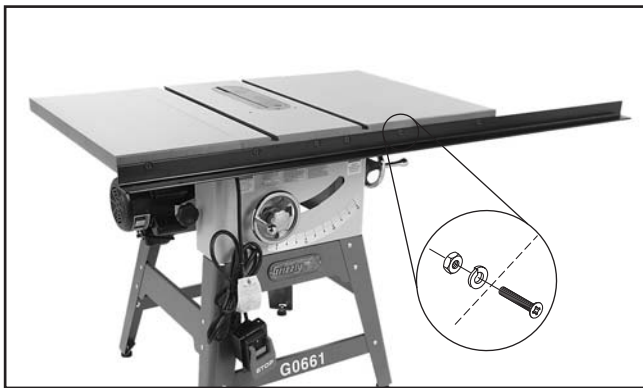

Figure 17. Front rail installed on saw.

14. Install the rear rail with six M8-1.25 x 25 flange cap screws, 8mm flat washers, and M8-1.25 hex nuts (**Figure 18**).

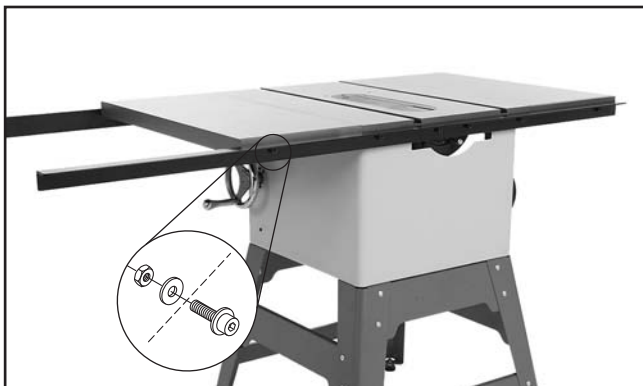

Figure 18. Rear rail installed on saw.

15. Install the fence tube on the front rail with six M8-1.25 x 10 flange bolts, as shown in **Figure 19**.

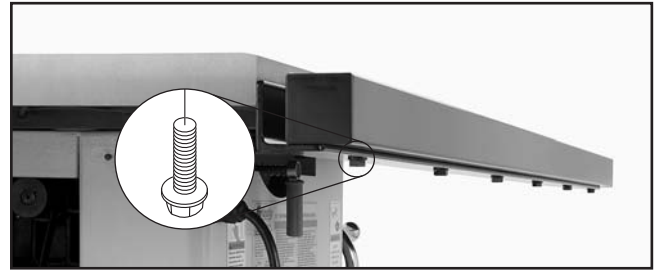

Figure 19. Fence tube installed on front rail.

16. Raise the blade up as far as it will go.
17. Install the fence lock handle (**Figure 20**) into the fence and place the fence on the rails, on the right-hand side of the blade.

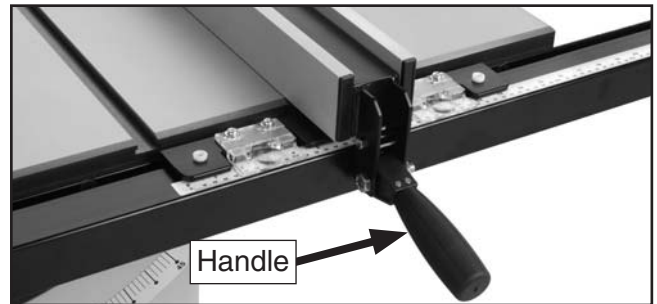

Figure 20. Fence lock handle installed on fence.

18. Remove the table insert by unscrewing the screw that fastens it to the table.
19. Use the included arbor wrench to remove the riving knife, which is installed for shipping purposes. (For more info on installing/removing the riving knife refer to **Page 21**.)

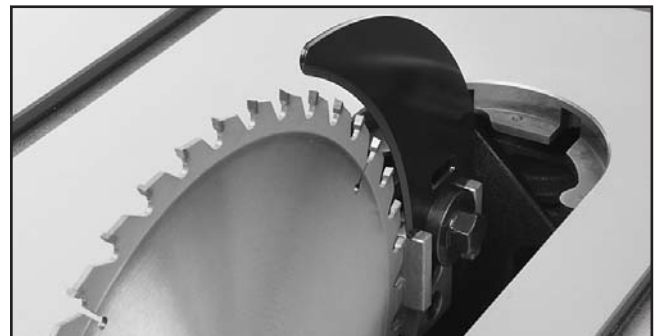

Figure 21. Riving knife.

20. Use both arbor wrenches to make sure the blade arbor nut is tight (hold the arbor with one of the wrenches on the left side of the blade to keep it from moving).



21. Slide the fence along the rail. If it drags across the table, then adjust the foot at the rear of the fence to raise the fence off of the table, but just enough so that the gap between the fence and the table is even from front to back.
22. The blade was set parallel to the miter slot at the factory. To verify that this setting did not move during shipping, slide the fence up against the edge of the miter slot, and lock it in place.

Note: *It's permissible for the back of the fence to pivot outward not more than 1/64" from being parallel to the blade. This creates a slightly larger opening between the fence and the blade, at the rear of the blade, to reduce the risk of workpiece binding or burning as it is fed through the cut. Many woodworkers intentionally set up their fence in this manner. Keep this in mind before adjusting your fence. For more details see **Figure 89** on **Page 52**.*

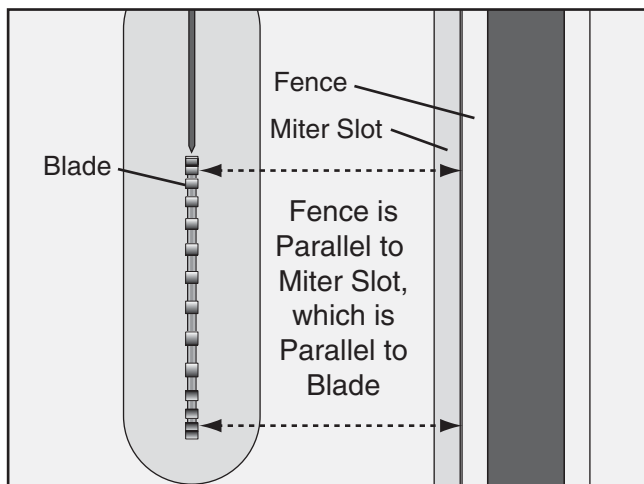

Figure 22. Checking fence parallelism with blade.

- If the fence/miter slot are still parallel to the blade, proceed to **Step 23**.
- If the fence is not parallel to the blade/miter slot, then you **MUST** adjust the fence as described in **Fence Adjustments** on **Page 51**, so that it is parallel to the blade.
- If the miter slot is not parallel with the blade, you must follow the procedures described in **Miter Slot to Blade Parallelism** on **Page 48**.

23. Install the blade guard assembly and replace the table insert. The blade guard, when properly installed, should look like **Figure 23**.

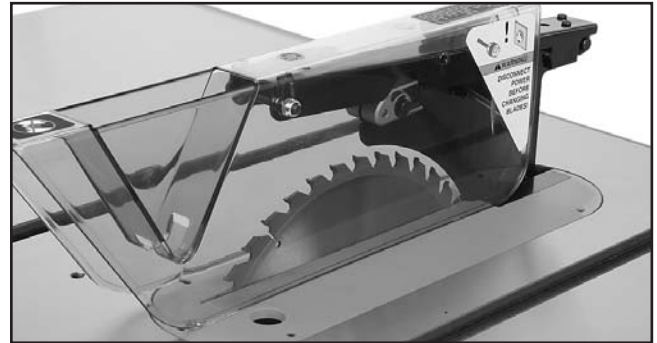

Figure 23. Blade guard assembly installed.

24. Adjust the table insert set screws to make sure it is flush with the table (use a straight-edge as a guide), then tighten the flat head screw to secure the table insert in place.

Note: *Do not over-tighten the flat head screw or it may lift the table insert.*

25. Place a straightedge against the blade and the splitter. When properly aligned, the splitter/riving knife will be in the "Alignment Zone," shown in **Figure 24**, and will be parallel with the blade.

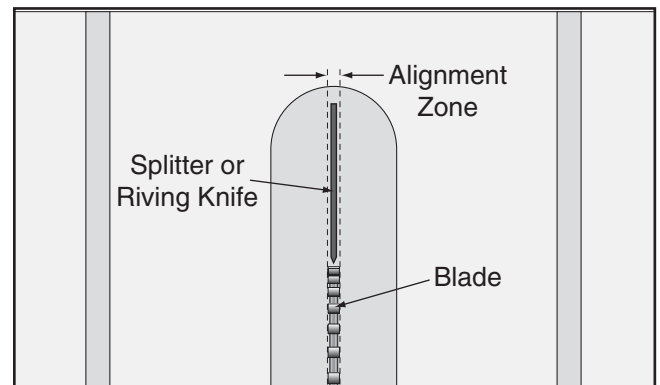

Figure 24. Splitter/riving knife alignment zone.

- If the splitter/riving knife is not inside the alignment zone, then it needs to be shimmed with the included metal shims. Proceed to **Shimming Splitter/Riving Knife** instructions on **Page 49**.
- If the splitter/riving knife is not parallel with the blade, then it needs to be straightened. Carefully bend the splitter into alignment by hand.



26. Attach the switch to the front rail with two M6-1 x 12 hex bolts (**Figure 25**).

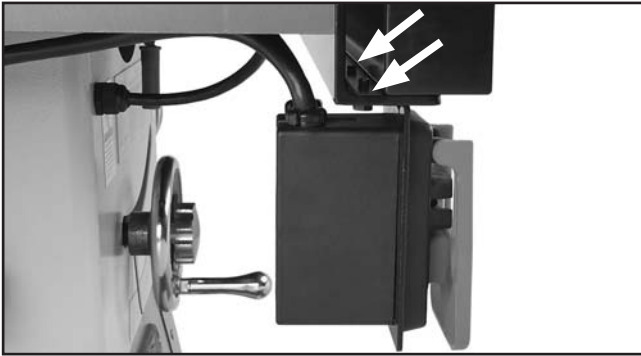

Figure 25. Switch attached to rails.

27. Install the motor cover by sliding the hinge posts into the hinges and locking the motor cover closed with the knob (**Figure 26**).



Figure 26. Motor cover installed on saw.

Dust Collection

⚠ CAUTION

DO NOT operate the Model G0661 without an adequate dust collection system. This saw creates substantial amounts of wood dust while operating. Failure to use a dust collection system can result in short and long-term respiratory illness.

Components and Hardware Needed:	Qty
Dust Hose 2½" (not included)	1
Hose Clamps 2½" (not included)	2
Dust Collection System (not included)	1

Recommended CFM at Dust Port: 150 CFM

Do not confuse this CFM recommendation with the rating of the dust collector. To determine the CFM at the dust port, you must consider these variables: (1) CFM rating of the dust collector, (2) hose type and length between the dust collector and the machine, (3) number of branches or wyes, and (4) amount of other open lines throughout the system. Explaining how to calculate these variables is beyond the scope of this manual. Consult an expert or purchase a good dust collection "how-to" book.

To connect a dust collection hose:

1. Fit a 2½" dust hose over the dust port, as shown in **Figure 27**, and tightly secure in place with a hose clamp.
2. Tug the hose to make sure it does not come off. **Note:** A tight fit is necessary for proper performance.



Figure 27. Dust hose attached to dust port.



Test Run

Once the assembly is complete, test run your machine to make sure it runs properly and is ready for regular operation.

The test run consists of verifying the following:
1) The motor powers up and runs correctly, and
2) the safety disabling mechanism on the switch works correctly.

If, during the test run, you cannot easily locate the source of an unusual noise or vibration, stop using the machine immediately, then review **Troubleshooting** on **Page 45**.

If you still cannot remedy a problem, contact our Tech Support at (570) 546-9663 for assistance.

To test run the machine:

1. Make sure you have read the safety instructions at the beginning of the manual and that the machine is setup properly.
2. Make sure all tools and objects used during setup are cleared away from the machine.
3. Connect the machine to the power source.
4. Verify that the machine is operating correctly by turning the machine **ON**.

—When operating correctly, the machine runs smoothly with little or no vibration or rubbing noises.

—Investigate and correct strange or unusual noises or vibrations before operating the machine further. Always disconnect the machine from power when investigating or correcting potential problems.

5. Turn the machine **OFF**.
6. Insert the switch disabling pin through the green ON button, as shown in **Figure 28**.



Figure 28. Switch disabling pin inserted into ON button.

7. Press the green ON button to test the disabling feature on the switch.
 - If the machine does not start, the switch disabling feature is working as designed.
 - If the machine starts, immediately stop the machine. The switch disabling feature is not working correctly. This safety feature must work properly before proceeding with regular operations. Call Tech Support for help.

Recommended Adjustments

For your convenience, the adjustments listed below have been performed at the factory and no further setup is required to operate your machine. However, because of the many variables involved with shipping, we recommend that you at least verify the following adjustments to ensure that the cutting you do with your new machine is safe and accurate.

Step-by-step instructions for these adjustments can be found in **SECTION 7: SERVICE**.

Adjustments that should be verified:

1. Blade Tilt Stop Accuracy (**Page 47**).
2. Miter Slot Parallel to Blade (**Page 48**).
3. Splitter/Riving Knife Alignment (**Page 49**).



SECTION 4: OPERATIONS

Operation Safety

!WARNING

Damage to your eyes, lungs, and ears could result from using this machine without proper protective gear. Always wear safety glasses, a respirator, and hearing protection when operating this machine.

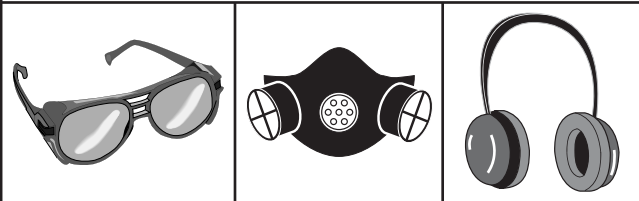

!WARNING

Loose hair and clothing can get caught in machinery and cause serious personal injury. Keep loose clothing and long hair away from machinery.

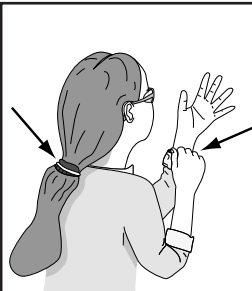

!WARNING

Keep the blade guard in the down position at all times. Failure to do this could result in serious personal injury or death.

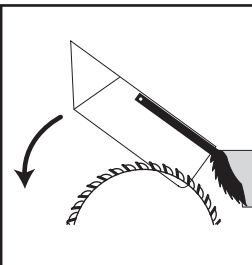

NOTICE

If you have never used this type of machine or equipment before, WE STRONGLY RECOMMEND that you read books, trade magazines, or get formal training before beginning any projects. Regardless of the content in this section, Grizzly Industrial will not be held liable for accidents caused by lack of training.

Basic Controls

ON/OFF Switch: Starts and stops the motor.

Safety Pin & Chain: When installed (Figure 29), disables the switch to prevent accidental startup.

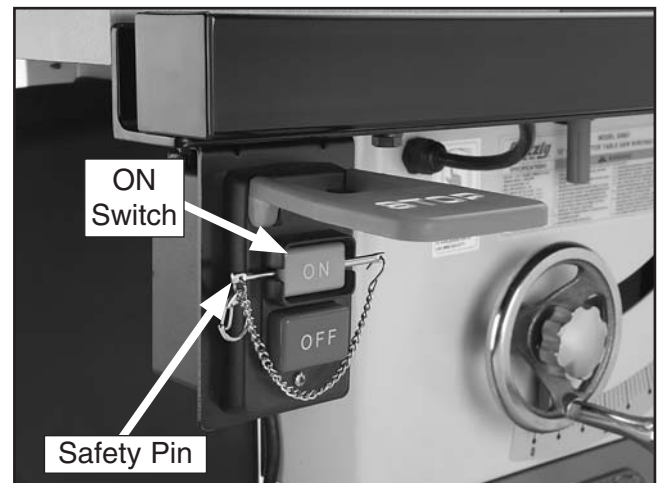

Figure 29. ON/OFF switch disabled.

Blade Tilt: To adjust the blade tilt, loosen the blade tilt lock, turn the blade tilt handwheel to position the blade at the desired angle, then tighten the lock shown in Figure 30.

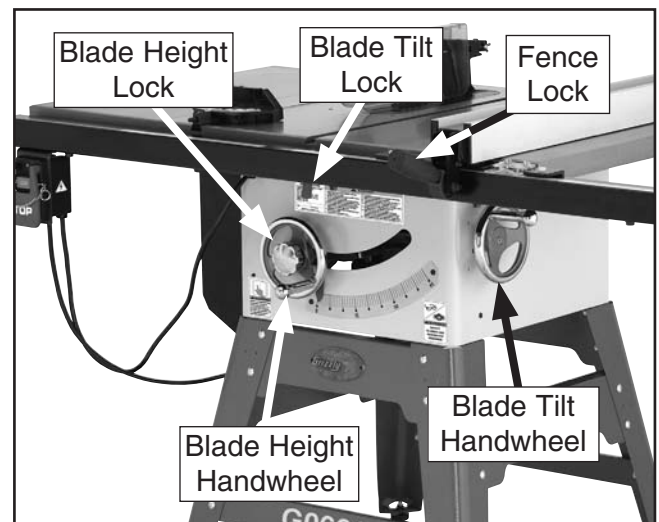

Figure 30. Basic table saw controls.



Blade Height: To set the blade height, unlock the blade height lock, turn the handwheel to set the blade height approximately 1/4" higher than the workpiece, then re-tighten the blade height lock.

Fence Lock: After adjusting the fence to the desired width of cut, lock it in place by firmly pushing the fence lock down until it stops.

Blade Selection

Ripping blade features:

- Best for cutting with the grain of the workpiece.
- 20-40 teeth.
- Flat-top ground tooth profile.
- Large gullets for large chip removal.

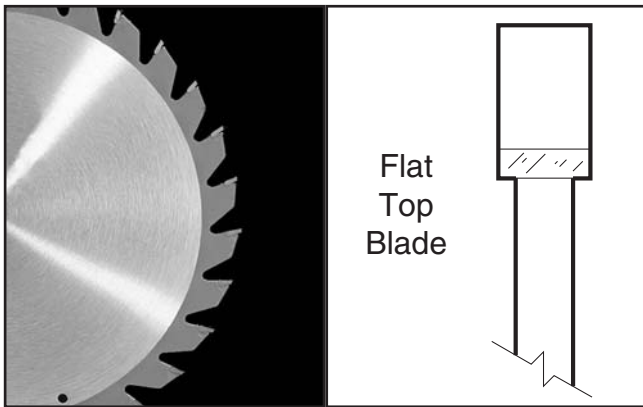

Figure 31. Ripping blade.

Crosscut blade features:

- Best for cutting across the grain of the workpiece.
- 60-80 teeth.
- Alternate top bevel tooth profile.
- Small hook angle and a shallow gullet.



Figure 32. Crosscutting blade.

Combination blade features:

- Adequate for cutting both with and across the grain.
- 40-50 teeth.
- Alternate top bevel and flat, or alternate top bevel and raker tooth profile.
- Teeth are arranged in groups of five.
- Gullets are small and shallow within the groups of five teeth, similar to a cross-cut blade; then large and deep between each group of five, like a ripping blade.

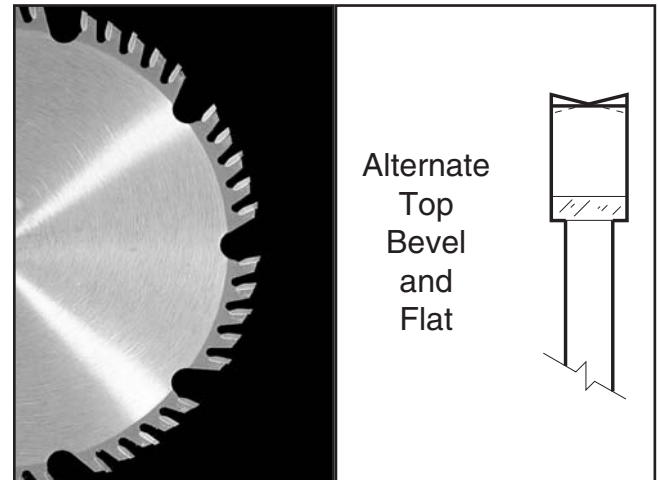

Figure 33. Combination blade.

Laminate blade features:

- Best for cutting plywood or veneer.
- 40-80 teeth.
- Triple chip tooth profile.
- Very shallow gullet.

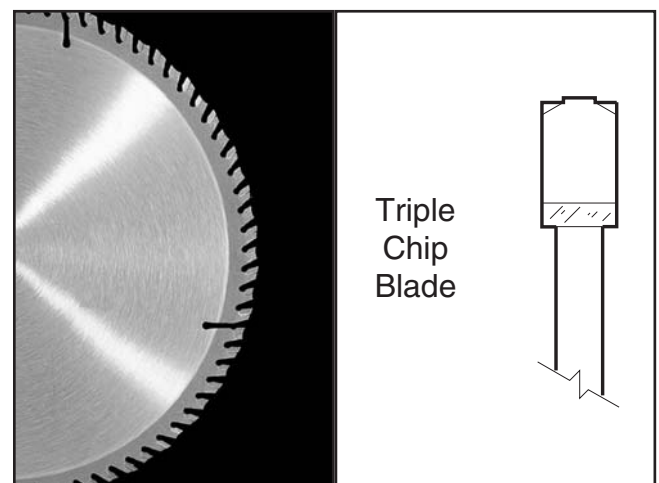

Figure 34. Laminate blade.



Dado Blades:

There are two types of dado blades: stacked and wobble.

- **Stacked Dado Blade:** These dedicated dado cutting blade sets consist of up to 8 individual blades. Multiple cutters are "stacked" between two outside blades. The width of the dado is determined by the combination of cutters that are "stacked" together. The dado is cut in a single pass, leaving a smooth and square channel in the face of the workpiece. Stacked dado blades are the most expensive option, but are worth considering if your projects require a lot of visible dado cuts. A stacked dado blade is shown in **Figure 35**.



Figure 35. Stacked dado blade.

- **Wobble Dado Blade:** Also a dedicated dado blade, a wobble blade usually consists of a single blade that is tilted on the arbor shaft while it is spinning. The channel is cut in the face of the workpiece as the blade passes through its pre-adjusted width of travel. Wobble blades are an inexpensive option when visibly pleasing channels are not a concern.

Thin Kerf Blade:

A blade with a kerf or thickness that is thinner than a standard blade. Since thin kerf blades are typically the same thickness of the splitter or riving knife—and in some cases thinner—we DO NOT recommend that they be used on this saw due to the increased risk of kickback.

Blade Installation

!WARNING

The saw blade is extremely sharp. Use extra care or wear gloves when handling the blade or working near it.

Review this section, even if your saw blade came pre-installed.

To install the blade:

1. DISCONNECT THE SAW FROM POWER!
2. Put on heavy leather gloves and raise the blade up.
3. Remove the table insert and blade guard/riving knife, depending on what is installed.
4. Use the arbor wrenches to loosen and remove the arbor nut, flange, and blade.

Note: *The arbor nut has right hand threads; turn it counterclockwise to loosen.*

5. Slide the blade over the arbor with the teeth facing the front of the saw, as shown in **Figure 36**.

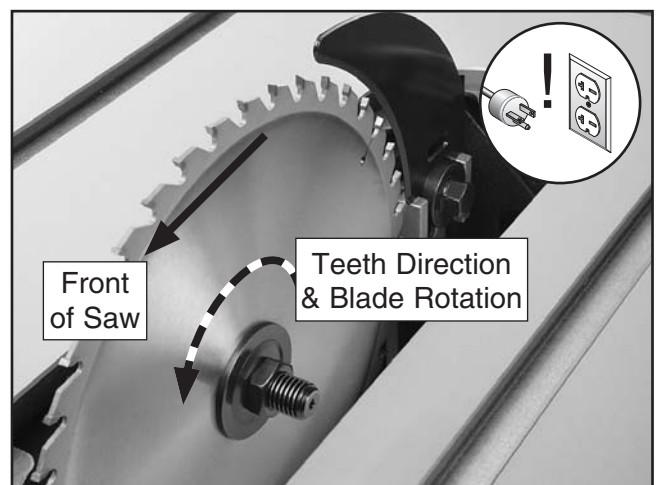

Figure 36. Correct blade direction.

6. Re-install the arbor flange and the arbor nut, and tighten them against the blade with the wrenches included with the saw. DO NOT overtighten.



Blade Guard Assembly

The term "blade guard" refers to the assembly that consists of the clear polycarbonate shield, the splitter, and the anti-kickback pawls on each side of the splitter (**Figure 37**). Each of these components have important safety functions during the operation of the saw.

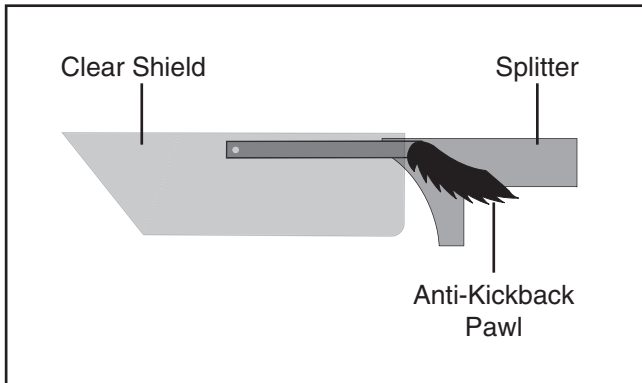

Figure 37. Blade guard assembly components.

Guard

The clear polycarbonate guard allows the operator to see the blade cut the workpiece during operation. This guard is designed to lift as the workpiece is pushed into the blade and remain in contact with the workpiece throughout the entire cut.

The guard reduces injury risk by providing a barrier around the blade that prevents accidental contact and contains flying wood chips.

To ensure that the guard does its job effectively, the guard must always be in the downward position while cutting, and the hinge mechanism must be maintained in good working condition so the guard can freely pivot up and down.

Splitter

The splitter is a metal plate that prevents the newly cut kerf of the workpiece from pinching the backside of the blade, causing kickback.

The splitter also acts as a barrier behind the blade to prevent hands from being pulled into the blade if a kickback occurs.

!WARNING

In order to work properly, the splitter cannot be bent or misaligned with the blade. If the splitter gets accidentally bent, take the time to straighten it or just replace it. Using a bent or misaligned splitter will increase the risk of kickback!

NOTICE

Some thin-kerf blades may be thinner than the thickness of the splitter. **DO NOT** install these blades on the saw, because the workpiece will hit the splitter during operation, possibly causing kickback. Always make sure the kerf of a blade you install is not thinner than the splitter.

Anti-Kickback Pawls

The anti-kickback pawls allow the workpiece to travel in only one direction. If the workpiece moves backwards, such as during a kickback, the pawls will dig into the workpiece to slow or stop it.

To work properly, the pawls must return to their bottom-most position after pivoting. If they fail to do this, the pivot spring may have been dislodged or broken and will need to be fixed/replaced.

When to Use the Blade Guard

The blade guard assembly **MUST** always be installed on the saw for all normal through cuts (those where the blade cuts all the way through the thickness of the workpiece).

When Not to Use the Blade Guard

The blade guard cannot be used on any non-through cuts (those in which the blade does not cut all the way through the thickness of the workpiece).

Sometimes the blade guard or its components can get in the way when cutting very narrow workpieces or other specialized cuts. Because the blade guard is provided to decrease your risk of injury, it should not be used if it gets in the way of making a safe cut. Use good judgement!

IMPORTANT: Whenever the blade guard cannot be used, the riving knife must be installed.



Riving Knife

The riving knife (**Figure 38**) works in the same manner as the blade splitter on the blade guard assembly. It is a metal plate that prevents the newly cut workpiece from pinching the backside of the blade and causing kickback.

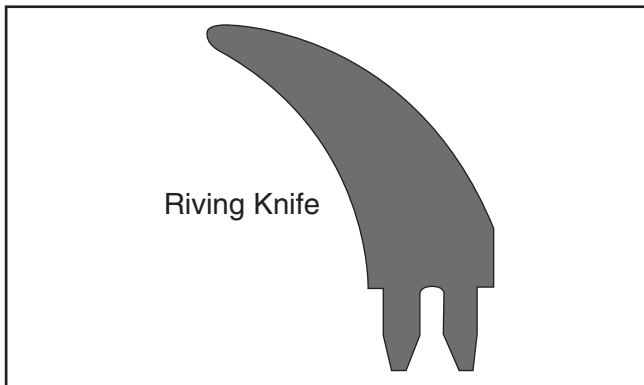

Figure 38. Illustration of a typical riving knife.

The key difference between the blade splitter and the riving knife is that the riving knife mounts below the blade's highest point of rotation, as shown in **Figure 39**.

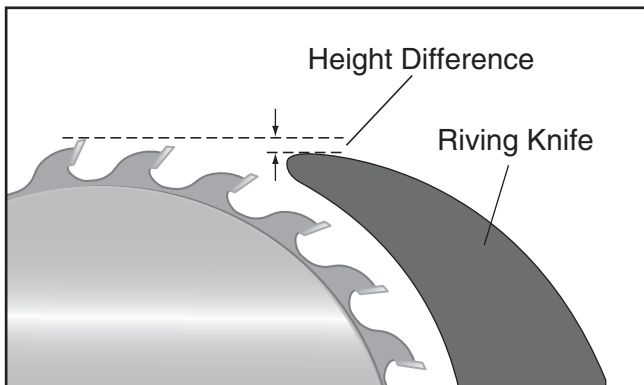

Figure 39. Height difference between riving knife and blade.

The height difference between the riving knife and the blade allows the workpiece to pass over the blade during non-through cuts (those in which the blade does not cut all the way through the thickness of the workpiece).

The riving knife also acts as a barrier behind the blade to reduce the risk of hands being pulled into the blade if a kickback occurs.

!WARNING

In order to work properly, the riving knife cannot be bent or misaligned with the blade. If the riving knife gets accidentally bent, take the time to straighten it or just replace it. Using a bent or misaligned riving knife will increase the risk of kickback!

NOTICE

Some thin-kerf blades may be thinner than the thickness of the riving knife. **DO NOT** install these blades on the saw, because the workpiece will hit the riving knife during operation, possibly causing kickback. Always make sure the kerf of a blade you install is not thinner than the riving knife.

When to Use the Riving Knife

Use the riving knife for all non-through cuts made with a standard table saw blade (i.e., dados or rabbet cuts in which a dado blade is NOT used, and when using a tenoning jig).

Also, use the riving knife for those special operations where the blade guard or its components get in the way of safe operation, such as with very narrow cuts.

When Not to Use the Riving Knife

The riving knife CANNOT be used with a dado blade. Otherwise, the riving knife height will exceed the blade height and the workpiece will hit the riving knife during the cut, forcing the operator into a dangerous situation of trying to turn the saw off with the workpiece stuck halfway through the cut.

In addition, although it is possible to use the riving knife for through cutting operations, the blade guard assembly offers far more injury protection and risk reduction than the riving knife. Therefore, **we strongly recommend** that you use the blade guard assembly instead of the riving knife for these types of cuts.



Workpiece Inspection

Some workpieces are not safe to cut or may require modification before they are safe to cut. **Before cutting, inspect all workpieces for the following:**

- **Material Type:** This machine is intended for cutting natural and man-made wood products, laminate covered wood products, and some plastics. Cutting drywall or cementitious backer board creates extremely fine dust and may reduce the life of the bearings. This machine is NOT designed to cut metal, glass, stone, tile, etc.; cutting these materials with a table saw may lead to injury.
- **Foreign Objects:** Nails, staples, dirt, rocks and other foreign objects are often embedded in wood. While cutting, these objects can become dislodged and hit the operator, cause kickback, or break the blade, which might then fly apart. Always visually inspect your workpiece for these items. If they can't be removed, DO NOT cut the workpiece.
- **Large/Loose Knots:** Loose knots can become dislodged during the cutting operation. Large knots can cause kickback and machine damage. Choose workpieces that do not have large/loose knots or plan ahead to avoid cutting through them.
- **Wet or "Green" Stock:** Cutting wood with a moisture content over 20% causes unnecessary wear on the blades, increases the risk of kickback, and yields poor results.
- **Excessive Warping:** Workpieces with excessive cupping, bowing, or twisting are dangerous to cut because they are unstable and often unpredictable when being cut. DO NOT use workpieces with these characteristics!
- **Minor Warping:** Workpieces with slight cupping can be safely supported if the cupped side is facing the table or the fence. On the contrary, a workpiece supported on the bowed side will rock during a cut and could cause kickback or severe injury.

Non-Through & Through Cuts

Non-Through Cuts

A non-through cut is a sawing operation where the blade does not protrude above the top face of the wood stock, as shown in **Figure 40**.

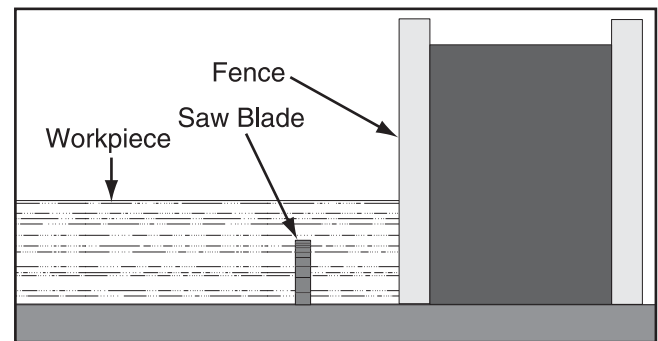

Figure 40. Example of a non-through cut.

Examples of non-through cuts include dados and rabbets. Non-through cuts have a higher risk of injury from kickback because the splitter and blade guard must be removed. When making non-through cuts with a standard blade, the riving knife **MUST** be installed. When making non-through cuts with a dado blade, extreme care, including using multiple light passes must be used, because neither the blade guard or riving knife can be used.

Through Cuts

A through cut is a sawing operation in which the workpiece is completely sawn through, as shown in **Figure 41**. Examples of through cuts are rip cuts, cross cuts, miter cuts, and beveled cuts. The blade guard assembly **MUST** be used when performing through cuts.

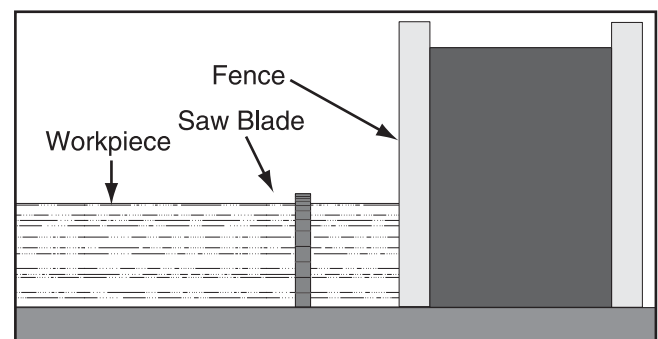

Figure 41. Example of a through cut (blade guard not shown for illustrative clarity).



Ripping

"Ripping" means cutting with the grain of a natural wood workpiece. In other man-made materials such as MDF or plywood, ripping simply means cutting lengthwise.

!WARNING

Serious injury can be caused by kickback. Kickback is a high-speed expulsion of stock from the table saw toward an operator. The operator or bystanders may be struck by flying stock, or the operator's hands can be pulled into the blade during kickback.

To make a rip cut:

1. Review **Preventing Kickback** on **Page 10** and take the necessary precautions to prevent kickback.
2. If using natural wood, joint one long edge of the workpiece on a jointer.
3. **DISCONNECT THE SAW FROM POWER!**
4. Ensure that the blade guard/splitter is installed.
5. Set the fence to the desired width of cut on the scale.
6. Adjust the blade height so the highest saw tooth protrudes approximately $\frac{1}{4}$ " above the workpiece.
7. Set up safety devices such as featherboards or other anti-kickback devices.
8. Rotate the blade to make sure it does not come into contact with any of the safety devices.
9. Plug the saw into the power source, turn it **ON**, and allow it to reach full speed.

Note: *The jointed edge of the workpiece must slide against the fence during the cutting operation.*

10. Use a push stick to feed the workpiece through the saw blade, as shown in **Figure 42**, until the workpiece is completely past the saw blade.

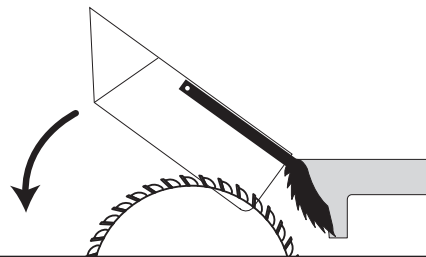

Figure 42. Typical ripping operation.

!WARNING

Turn OFF the saw and allow the blade to come to a complete stop before removing the cut-off piece. Failure to follow this warning could result in serious personal injury.

!WARNING



Keep the blade guard installed and in the down position. Failure to do this could result in serious personal injury or death.



Crosscutting

"Crosscutting" means cutting across the grain of a natural wood workpiece. In other man-made materials, such as MDF or plywood, crosscutting means cutting across the width of the workpiece.

To make a crosscut using the miter gauge:

1. DISCONNECT THE SAW FROM POWER!
2. Ensure that the blade guard/splitter is installed.
3. Move the rip fence aside and position the miter gauge, adjusted to 90°, in a miter slot.
4. Adjust the blade height so the teeth protrude approximately 1/4" above the workpiece.
5. Slide the miter gauge near the blade and adjust the workpiece so the blade will cut on the waste side of the line.
6. Plug in the table saw, turn it **ON**, and allow it to reach full speed.
7. Hold the workpiece firmly against the face of the miter gauge (**Figure 43**), and ease it through the blade until the workpiece is completely past the saw blade.

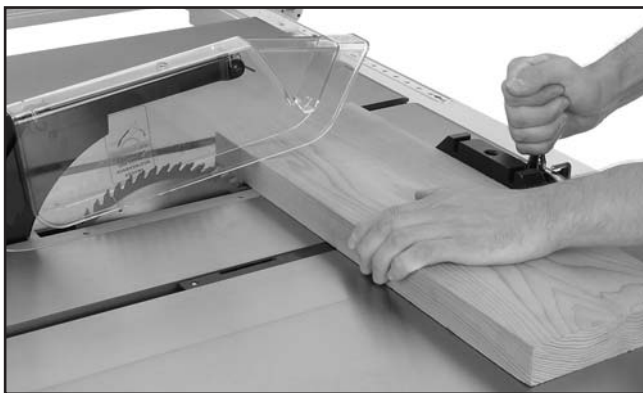

Figure 43. Typical crosscutting operation.

⚠️ WARNING

Turn **OFF** the saw and allow the blade to come to a complete stop before removing the cut-off piece. Failure to follow this warning could result in serious personal injury

Miter Cuts

A miter is an angled crosscut. Miters are usually cut in the same manner as crosscuts, using the miter gauge and a predetermined mark on the workpiece.

To perform a miter cut:

1. DISCONNECT THE SAW FROM POWER!
2. Ensure that the blade guard/splitter is installed.
3. Determine the angle of your cut. If the angle needs to be very precise, use a protractor to set the miter gauge to the blade.
4. Place the face of the miter gauge against the edge of the workpiece and place the bar across the face of the workpiece. Use the bar as a guide to mark your cut, as shown in **Figure 44**.



Figure 44. Example of marking miter line.

5. Place the miter gauge back into the slot and hold the workpiece firmly against the miter gauge body. Slide the miter gauge near the blade and adjust the workpiece so the blade will cut on the waste side of the line.
6. Proceed to make the cut in the same manner as described in the **Crosscutting** instructions.



Blade Tilt/Bevel Cuts

When the blade tilt stop bolts are properly adjusted (**Page 47**), the blade tilt handwheel allows the operator to tilt the blade to the left, anywhere between 0° and 45°. This is used most often when cutting bevels, compound miters or chamfers. **Figure 45** shows an example of the blade when tilted to 45°.



Figure 45. Blade tilted to 45° for bevel cutting on a typical table saw.

Dado Cutting

Commonly used in furniture joinery, a dado is a straight channel cut in the face of the workpiece. Dadoes can be cut using either a dedicated dado blade or a standard saw blade. The included dado table insert must be installed and used when a dado blade is installed—unless a zero clearance table insert is used instead.

The table saw motor is pushed to its limits when making a dado cut. If the motor starts to bog down, slow down your feed rate and make multiple shallow passes. **DO NOT use a dado blade larger than 8" in diameter!** The saw and arbor are not intended to safely use a larger dado blade.

!WARNING

Dado operations require proper procedures to avoid serious injury. Extra care must be taken to prevent kickback when using dado blades. Any movement of the workpiece away from the fence will cause kickback. Be certain that stock is flat and straight. Failure to follow these warnings could result in serious personal injury.

!WARNING

DO NOT make a through-cut with a dado blade. Dado blades are not designed for through cuts. Failure to follow this warning could result in serious personal injury.

!CAUTION

Always use push sticks, featherboards, push paddles and other safety accessories whenever possible to increase safety and control during operations that require the blade guard and splitter to be removed from the saw. **ALWAYS** replace the blade guard after dadoing is complete.

Using a Stacked or Wobble Dado Blade

1. DISCONNECT THE SAW FROM POWER!
2. Remove the table insert, the blade guard assembly or riving knife, and the saw blade.
3. Attach and adjust the dado blade system according to the dado blade manufacturer's instructions. **DO NOT use a dado blade larger than 8" in diameter on this saw!** The saw and arbor are not intended to safely use a larger dado blade.
4. Install the dado table insert.
5. Raise the dado blade up to the desired depth of cut (depth of dado channel desired). When cutting deep dadoes, take more than one pass to reduce the risk of kickback.

!WARNING

The danger of kickback increases relative to the depth and width of a cut. Reduce the risk of kickback by making multiple shallow cuts to achieve the desired depth of cut. Failure to follow these warnings could result in serious personal injury.



- Adjust the distance between the fence and the inside edge of the blade, as shown in **Figure 46**, to dado the length of a workpiece.

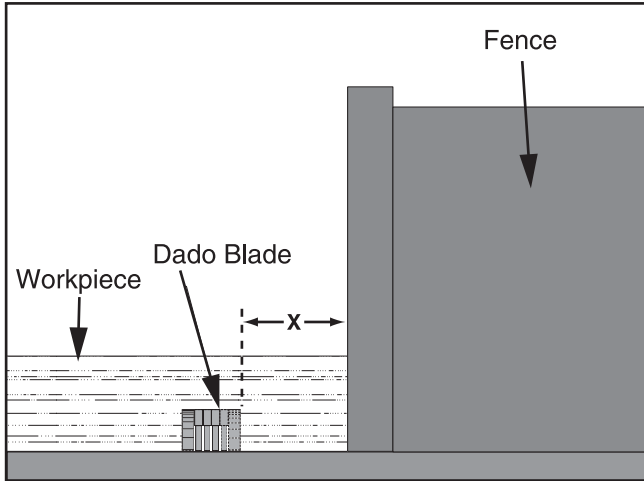

Figure 46. Stacked or wobble dado cut.

- If dadoing across the workpiece, use the miter gauge and carefully line up the desired cut with the dado blade. **DO NOT** use the fence in combination with the miter gauge.

!WARNING

Never try to dado a board that is not flat by holding it down against the table. If kickback occurs, your hand will likely be pulled into the blade, resulting in serious personal injury.

!CAUTION

Always use push sticks, featherboards, push paddles and other safety accessories whenever possible to increase safety and control during operations that require the blade guard and splitter to be removed from the saw. **ALWAYS** replace the blade guard after dadoing is complete.

- Reconnect the saw to the power source.
- Turn the saw **ON**. The blade should run smooth, with no vibrations.
- When the blade has reached full speed, perform a test cut with a scrap piece of wood.
- If the cut is satisfactory, repeat the cut with the actual workpiece.

Using a Standard Saw Blade to Cut Dados

Note: Reduce motor overloading and blade wear by using a ripping blade. Ripping blades are designed to clear the sawdust quickly. See **Page 24** for more details.

To cut a dado with a standard blade:

- DISCONNECT THE SAW FROM POWER!**
- Ensure that the riving knife and standard table insert are installed.
- Mark the width of the dado cut on the workpiece. Include marks on the edge of the workpiece so the cut path can be aligned when the workpiece is lying on the table. Raise the blade up to the desired depth of cut (depth of dado channel desired). When cutting deep dados, take more than one pass to reduce the risk of kickback.

!WARNING

The danger of kickback increases relative to the depth and width of a cut. Reduce the risk of kickback by making multiple shallow cuts to achieve the desired depth of cut. Failure to follow these warnings could result in serious personal injury.

- If dadoing across the workpiece, use the miter gauge to support the workpiece, and align the blade to cut one of the dado sides. **DO NOT** use the fence in combination with the miter gauge.



- If dadoing the length of a workpiece, align the blade to cut one of the dado sides, as shown in **Figure 47**.

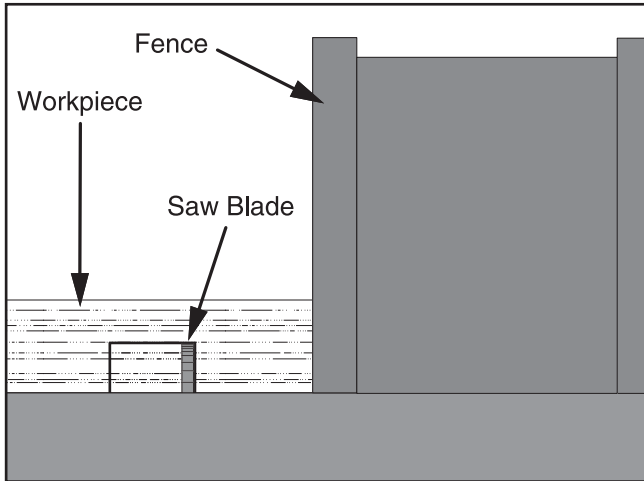

Figure 47. Single-blade dado first cut.

- Reconnect the saw to the power source and turn the saw **ON**. Allow the blade to reach full speed.
- Perform the cutting operation.
- Re-adjust the fence so the blade is aligned with the other edge of the intended dado channel (**Figure 48**).

Note: Be sure to keep the cuts within your marks; otherwise, the dado will be too big.

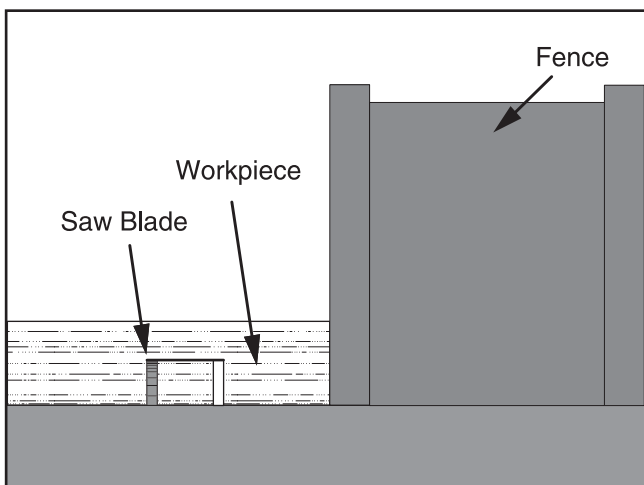

Figure 48. Single-blade dado second cut.

- Continue making cuts toward the center of the dado until the dado is complete.

Rabbet Cutting

⚠ WARNING

You may experience kickback during this procedure. Stand to the side of the blade and wear safety glasses or a face shield to prevent injury when cutting rabbets. Do not put hands behind blade!

Commonly used in furniture joinery, a rabbet is an L-shaped groove cut in the edge of the workpiece. Rabbets can be cut with either a dado blade or a standard saw blade.

Note: Rabbet cutting requires the use of a sacrificial fence attachment, as shown in **Figure 49**.

Cutting Rabbets with Dado Blade

- DISCONNECT THE SAW FROM POWER!
- Lower the blade completely, then install the dado blade and dado table insert or a zero clearance fence. **DO NOT use a dado blade larger than 8" in diameter on this saw!**
- Make the sacrificial fence the same length as the fence and $\frac{3}{4}$ " thick.
- Attach the sacrificial fence to the rip fence with clamps, as shown in **Figure 49**, making sure they are all secure and tight.

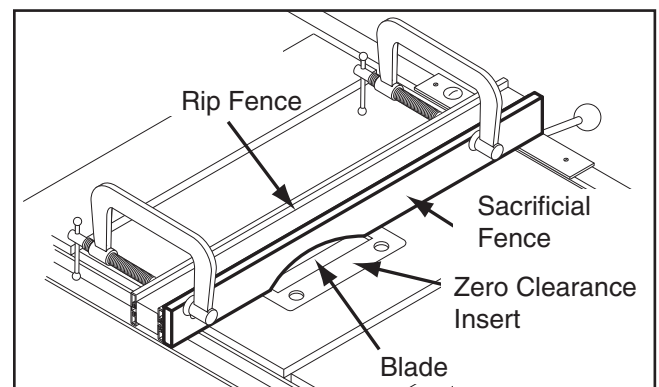

Figure 49. Sacrificial fence.

- Adjust the fence, turn the saw **ON**, raise the blade into the sacrificial fence to the height needed for the rabbeting operation, and turn the saw **OFF**.



6. DISCONNECT THE SAW FROM POWER!

⚠ CAUTION

Always use push sticks, featherboards, push paddles and other safety accessories whenever possible to increase safety and control during operations that require the blade guard and splitter to be removed from the saw. ALWAYS replace the blade guard after dadoing is complete.

7. Align the workpiece to perform the cutting operation, as shown in **Figure 50**.

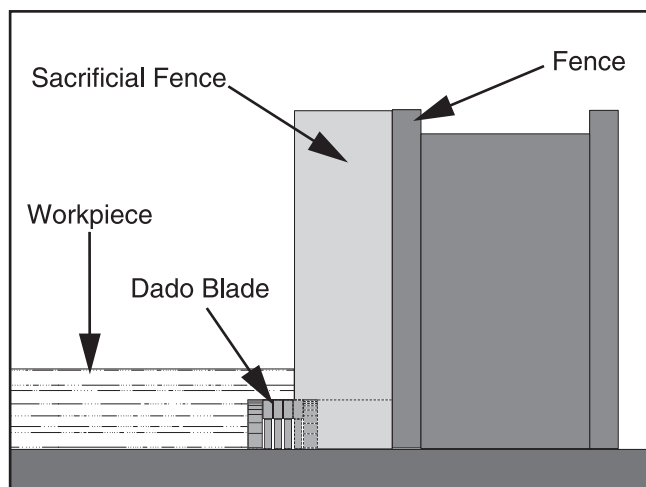

Figure 50. Rabet cutting.

⚠ WARNING

The danger of kickback increases relative to the depth and width of a cut. Reduce the risk of kickback by making multiple passes to achieve the desired depth of cut. Failure to follow these warnings could result in serious personal injury.

8. Reconnect the saw to the power source and turn the saw **ON**.
9. When the blade has reached full speed, perform a test cut with a scrap piece of wood.
10. If the cut is satisfactory, repeat the cut with the final workpiece.

Cutting Rabbets with Standard Blade

Note: Reduce motor overloading and blade wear by using a ripping blade. Ripping blades are designed to clear the sawdust quickly.

To cut a rabet with a standard blade:

1. DISCONNECT THE SAW FROM POWER!
2. Ensure that the riving knife and standard insert are installed.
3. Clearly mark the width of the rabet cut on the workpiece.

Note: Include marks on the edge of the workpiece to clearly identify the intended cut while it is laying flat on the saw table.

4. Raise the blade up to the desired depth of cut (depth of rabet channel desired). When cutting deep rabbets, take more than one pass to reduce the risk of kickback.

⚠ WARNING

The danger of kickback increases relative to the depth of a cut. Reduce the risk of kickback by making multiple passes to achieve the desired depth of cut. Failure to follow these warnings could result in serious personal injury.

5. Adjust the fence so the blade is aligned with the inside of your rabet channel, as shown in **Figure 51**.

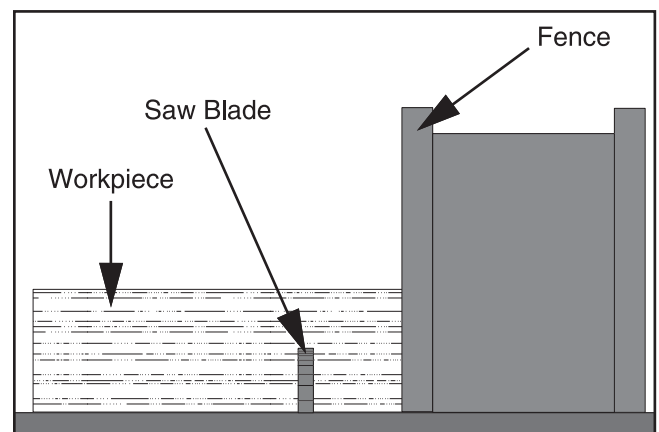

Figure 51. Rabet cutting with a standard blade.



6. Reconnect the saw to the power source and turn the saw **ON**.
7. When the blade has reached full speed, perform a test cut with a scrap piece of wood.
8. If the cut is satisfactory, repeat the cut with the final workpiece.
9. Stand the workpiece on edge as shown in **Figure 52**.

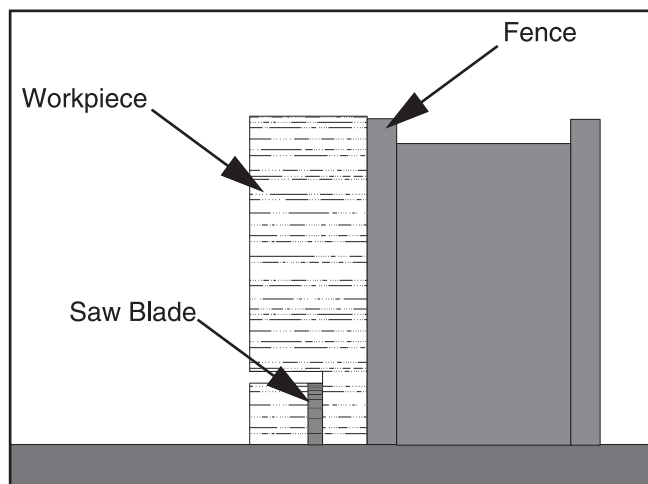

Figure 52. Second cut to create a rabbet.

10. Adjust the saw blade height to intersect with the first cut.
11. Perform the second cut to complete the rabbet.

Resawing

!WARNING

Resawing on a table saw increases the chances of kickback. Serious injury can be caused by kickback. Kickback is a high-speed expulsion of stock from the table saw toward an operator. The operator or bystanders may be struck by flying stock, or the operator's hands can be pulled into the blade during kickback.

!WARNING

Resawing operations require proper procedures to avoid serious injury. Extra care must be taken to prevent kickback when resawing. Any tilting or movement of the workpiece away from the fence will cause kickback. Be certain that stock is flat and straight. Failure to follow these warnings could result in serious personal injury.

Resawing is the process of cutting a thick piece of stock into one or more thinner pieces. **Bandsaws are ideal for resawing and the process is fairly easy and safe. A table saw is not intended for resawing and the process is difficult and extremely dangerous.** Resawing on the table saw often binds the blade, causing kickback. The risk of kickback increases relative to the depth of a cut. Kickback is more dangerous when resawing on a table saw because the anti-kickback devices and blade guard must be removed, leaving no protection between your hands and the saw blade. Kickback can pull the operator's hands into the blade, or the operator or bystanders may be hit by flying stock. **DO NOT** resaw on a table saw without using a resaw barrier. **DO NOT** resaw on a table saw without wearing a full face shield.

The following instructions describe how to build a resaw barrier, add an auxiliary fence to your standard fence, and more safely perform resawing operations.

Note: This table saw can only resaw wood that is less than 6³/₈" tall.



Resaw Barrier

The resaw barrier shown in **Figure 53** holds the workpiece vertical, keeps it aligned with the fence, and keeps your hands away from the blade.

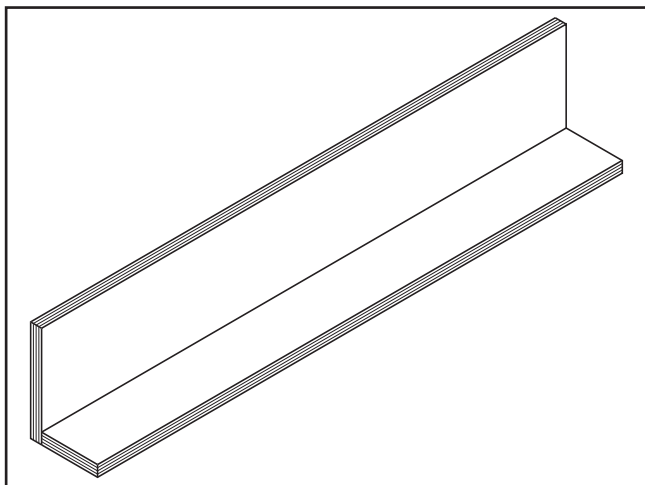

Figure 53. Resawing barrier.

Components Needed for the Resaw Barrier:

Hardwood or Plywood $\frac{3}{4}$ " x 6" x 34"	1
Hardwood or Plywood $\frac{3}{4}$ " x 3" x 34"	1
Wood Screws $\frac{1}{4}$ -20 x 2"	8
Wood Glue	As Needed

Tools Needed for the Resaw Barrier:

Table Saw	1
Jointer and Planer	Recommended
Clamps	2 Minimum
Drill and Drill Bits	1

To build the resaw barrier:

1. Cut two boards to $\frac{3}{4}$ " x 6" x 34" and $\frac{3}{4}$ " x 3" x 34". If you are using hardwood, cut the boards oversize, then joint and plane the boards to the correct size to make sure the boards are square and flat.

Note: Only use furniture grade plywood or kiln dried hardwood to prevent warping.

2. Pre-drill and countersink 8 holes approximately $\frac{3}{8}$ " from the bottom of the 6" tall board. These will be used as pilot holes when attaching the board to another piece in the next step.

3. Glue the end of the 3" board, then clamp the boards at a 90° angle with the larger board in the vertical position, as shown in **Figure 54**.

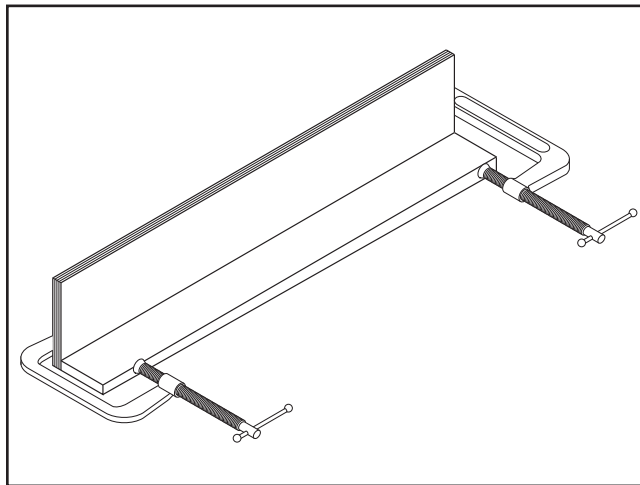

Figure 54. Clamping the resawing barrier.

4. Secure the joint with wood screws through the holes you drilled in **Step 2**.

Auxiliary Fence

The auxiliary fence is necessary if you are resawing a workpiece that is taller than it is wide. It should be no less than $\frac{1}{2}$ " shorter than the board to be resawn.

Components Needed for the Auxiliary Fence:

Hardwood or Plywood $\frac{3}{4}$ " x (Height) x 34"	1
------------------------------------------------------	---

Tools Needed for the Resaw Barrier:

Table Saw	1
Jointer and Planer	Recommended
Clamps	2 Minimum
Router	1
T-Slot Bit	1

To build the auxiliary fence:

1. Cut a $\frac{3}{4}$ " thick board 34" long, and cut a height no less than $\frac{1}{2}$ " shorter than the board to be resawn. If you are using hardwood, cut the board oversize, then joint and plane the board to the correct size to make sure the board is square and flat.

Note: Only use furniture grade plywood or kiln dried hardwood to prevent warping.



2. Remove the fence assembly and turn it upside down and notice the openings on the underside of the fence that allow access to the mounting hardware.
3. Unthread the fence face mounting hardware and remove the fence face from the fence assembly.
4. Install the fence on the rail and measure the height of the fence face mounting hole from the table top.
5. Subtract 1/8" from the distance measured in **Step 4** and transfer this distance to the wood piece that will be your auxiliary fence. This mark will be the centerline for the T-slot you need to make in the next step, which will allow you to mount the auxiliary fence to the main fence assembly.
6. Rout a T-slot in your auxiliary fence on the centerline you created in **Step 5**.
7. Place the auxiliary fence next to the open side of the fence and mark the location of four mounting holes on the auxiliary fence.
8. Use the mounting hardware that had previously attached the fence face to attach the auxiliary fence. The end result should be similar to **Figure 55**.

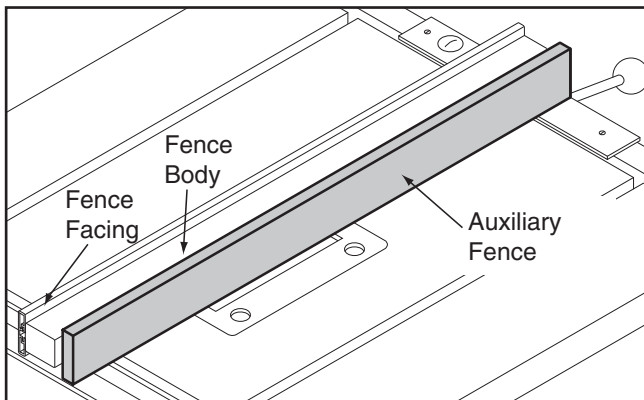

Figure 55. Auxiliary fence.

Resawing Operations

The table saw motor is pushed to its limits when resawing. If the motor starts to bog down, slow down your feed rate. Motor overloading and blade wear can be reduced by using a ripping blade. Ripping blades are designed to clear the sawdust quickly.

Components Needed for Resawing:

Zero Clearance Insert.....	1
Ripping Blade 10".....	1
Clamps	2
Shop Made Auxiliary Fence	1
Shop Made Resaw Barrier	1

!WARNING

You may experience kickback during this procedure. Stand to the side of the blade and wear a full face shield to prevent injury when resawing.

To perform resawing operations:

1. DISCONNECT THE SAW FROM POWER!
2. Remove the standard table insert and the blade guard assembly, and install the riving knife. Install a ripping blade and the optional Model T20818 zero clearance table insert, then lower the blade below the table.
3. Attach the auxiliary fence to the standard fence and set it to the desired width.

Note: When figuring out the correct width, don't forget to account for blade kerf and the inaccuracy of the fence scale while the auxiliary fence is installed.

4. Place the workpiece against the auxiliary fence and slide the resaw barrier against the workpiece, as shown in **Figure 56**. Now clamp the resaw barrier to the top of the table saw at both ends.

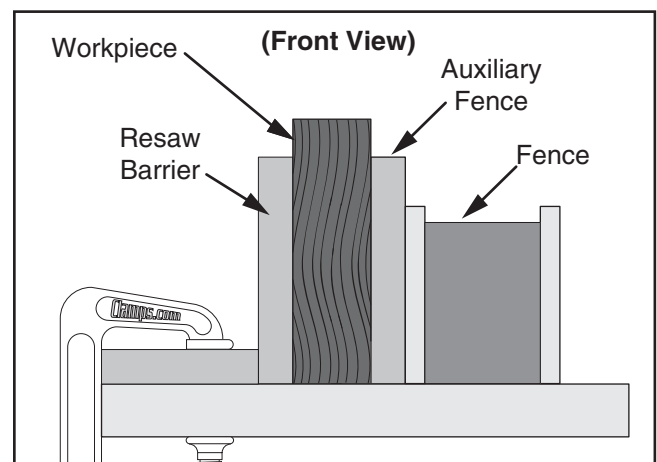

Figure 56. Ideal resaw workpiece setup.



5. Slide the workpiece over the blade to make sure it moves smoothly, then remove the workpiece.
6. Raise the blade approximately an inch, or close to half the height of the workpiece (**Figure 57**), whichever is less.

!WARNING

The danger of kickback increases relative to the depth of a cut. Reduce the risk of kickback by making multiple passes to achieve the desired depth of cut. Failure to follow these warnings could result in serious personal injury.

!CAUTION

Always use push sticks or push paddles to increase safety and control during operations which require that the blade guard and splitter must be removed from the saw. **ALWAYS** replace the blade guard after resawing is complete.

7. Plug in the table saw, turn it **ON**, and use a push stick to feed the workpiece through the blade, using a slow and steady feed rate.
8. Flip the workpiece end for end, keeping the same side against the fence, and run the workpiece through the blade.

9. Repeat **Steps 6–8** until the blade is close to half of the height of the board to be resawn. The ideal completed resaw cut will leave an $\frac{1}{8}$ " connection when the resawing is complete as shown in **Figure 57**. Leaving an $\frac{1}{8}$ " connection will reduce the risk of kickback.

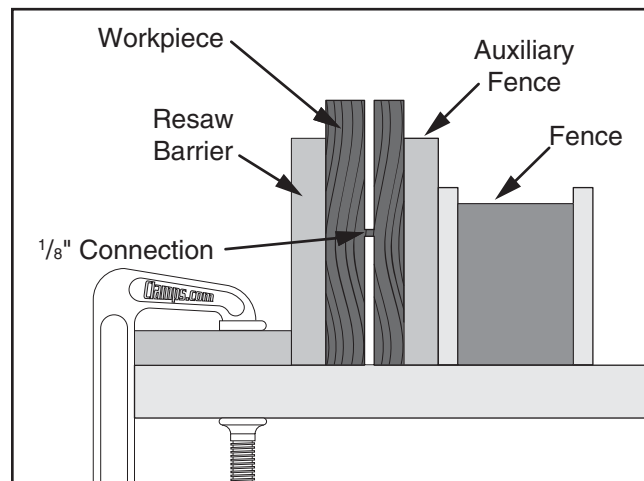

Figure 57. Ideal completed resaw cut.

10. Turn **OFF** the table saw, then separate the parts of the workpiece and hand plane the remaining ridge to remove it.
11. When finished resawing, remove the resaw barrier and auxiliary fence, then re-install the blade guard/splitter or riving knife and standard table insert.



SECTION 5: ACCESSORIES

Aftermarket Accessories

H7583—Grizzly Tenoning Jig

Our fully adjustable tenoning jig handles stock up to 3/4" thick and features an adjustable bevel angle with a 90° to 75° range. The two large grip handles, adjustable guide bar, multi-position control levers, and extra large clamping handwheel will ensure accurate and repeatable results. A top seller!

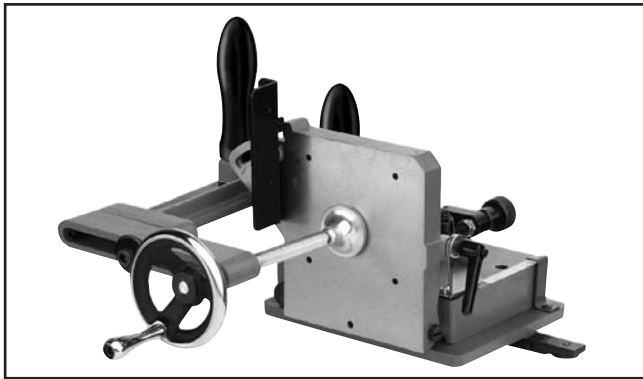

Figure 58. Model H7583 Tenoning Jig.

T20392—Success with Tablesaws

The table saw is the cornerstone of any workshop, yet, too many woodworkers still haven't learned just how versatile this tool really is. This indispensable handbook explains how to choose and set up the right saw for any shop, and demonstrates basic and advanced techniques for ripping, crosscutting, and cutting bevels and mitered edges. 176 pgs.

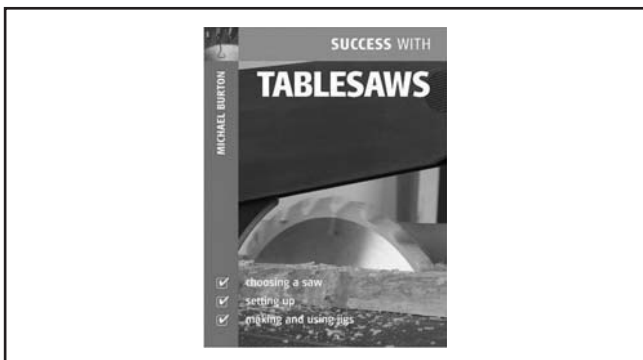

Figure 59. Model T20392 Success with Tablesaws guide book.

Carbide-Tipped ATB Circular Saw Blades

H9144—10" Ripping Blade, 30T

H9145—10" General Purpose, 40T

H9146—10" Fine Finishing/Cabinet Work, 60T

H9147—10" Cabinet Work/Trimming, 80T

H9148—10" Super Fine Work/Trimming, 100T

We looked long and hard for a high quality, heavy-duty, balanced woodworking saw blade that brings precision into the price range of most woodworkers. Now, for the cost of a construction quality blade, you can enjoy the benefits of a saw blade designed for precision woodworking. Alternate top bevel. 10" diameter, 5/8" arbor.



Figure 60. Carbide-tipped saw blades.

H8029—5 Piece Safety Kit

This kit has four essential jigs. Includes two push blocks, push stick, featherboard and combination saw and router gauge. Featherboard fits 3/8" x 3/4" miter slots. Made of high visibility yellow plastic.



Figure 61. H8029 5 Piece Safety Kit.



H7777—Grizzly 8" Stack Dado Set

Finally, a stack dado set that everyone can afford! The set includes two 1/8" wide 30 tooth blades, four 1/8" wide chip cutters, one 3/32" wide chip cutter, one 1/16" wide chip cutter and two each copper shims in .005", .010", .015" and .020" thicknesses. Bore is 5/8". Can cut dados from 1/8" to 3/4".



Figure 62. H7777 Grizzly stack dado set.

G2370—SHOP FOX® Board Buddies-Yellow

These unique hold downs only turn in one direction to prevent kickback. Adjustable height, spring loaded wheels are designed to hold your workpiece tight against the table and rip fence and are made of a special composition that will not mark your work.



Figure 63. G2370 SHOP FOX® Board Buddies.

Call 1-800-523-4777 To Order

T20501—Face Shield Crown Protector 4"

T20502—Face Shield Crown Protector 7"

T20503—Face Shield Window

T20448—Economy Clear Safety Glasses

T20452—"Kirova" Anti-Reflective Glasses

T20456—"Dakura" Clear Safety Glasses

H0736—Shop Fox® Safety Glasses

These glasses meet ANSI Z87.1-2003 specifications. Buy extras for visitors or employees. You can't be too careful with shop safety!



Figure 64. Our most popular eye protection.

T20514—Small Half-Mask Respirator

T20515—Medium Half-Mask Respirator

T20516—Large Half-Mask Respirator

T20511—Pre-Filter P100

T20539—Cartridge Filter 2PK P100

T20541—Cartridge Filter 2PK P100 & O Vapor

Wood and other types of dust can cause severe respiratory damage. If you work around dust everyday, a half-mask respirator can greatly reduce your risk. Compatible with safety glasses!



Figure 65. Half-mask respirator with disposable cartridge filters.



- G5562—SLIPIT® 1 Qt. Gel
- G5563—SLIPIT® 12 oz Spray
- G2871—Boeshield® T-9 12 oz Spray
- G2870—Boeshield® T-9 4 oz Spray
- H3788—G96® Gun Treatment 12 oz Spray
- H3789—G96® Gun Treatment 4.5 oz Spray



Figure 66. Recommended products for protecting your cast iron table top.

G7314—Heavy-Duty SHOP FOX® Mobile Base
 Make your machine mobile with this popular patented mobile base. The unique outrigger type supports increase stability and lower machine height. This heavy duty mobile base is rated for up to a 600 lb. capacity.



Figure 67. G7314 SHOP FOX® Mobile Base.

T20818—Zero Clearance Insert for G0661
 Zero clearance table inserts are important accessories for eliminating the gap between the blade and the table, which results in tear-out free cuts and a reduced risk of kickback from cutting narrow stock. Perfectionist woodworkers have a different table insert for each type of cut!

- G7581—Superbar
- G7582—Master Plate

The miter slot mounted Superbar™ will allow you to align, tune and calibrate your table saw to within ±.001 in just minutes. Replace your table saw blade when calibrating the double disk ground Master Plate for a precision measurement, with no runout!

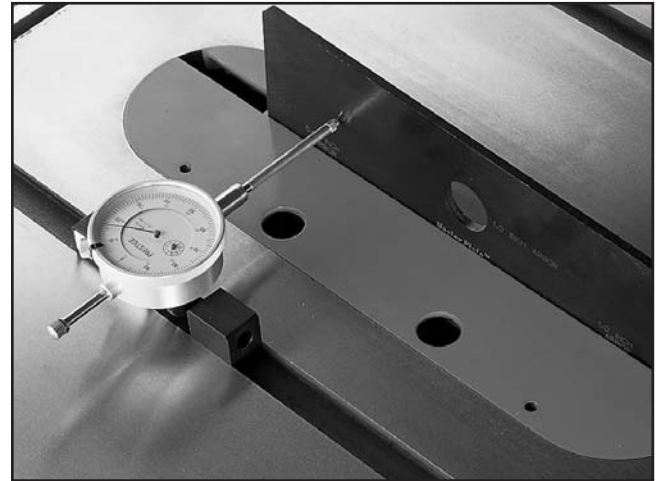

Figure 68. Superbar™ and Master Plate.

- H1049—Clear Flexible Hose 2½" x 10'
- H1052—Clear Flexible Hose 4" x 10'
- G3123—Black Flexible Hose 2½" x 10'
- G1536—Black Flexible Hose 4" x 10'
- G3124—Wire Hose Clamp 2½"
- G2974—Wire Hose Clamp 4"
- G3119—Dust Collection Adapter 2½" x 4"
- G1843—Plastic Blast Gate 4"
- G4679—Anti-Static Grounding Kit
- G7938—Shop Vacuum Adapter 2½" x 2½"

We've hand picked a selection of dust collection components commonly needed to connect the Model G0661 to an existing dust collection system.



Figure 69. Dust collection accessories.



Shop Made Safety Accessories

Push Stick

Using a push stick is essential to safe table saw operations, especially when cutting narrow cuts. The beauty of a push stick is that it keeps your hand well away from the blade during the cut, and if there is contact with the blade, the push stick will take the damage rather than your fingers or hand.

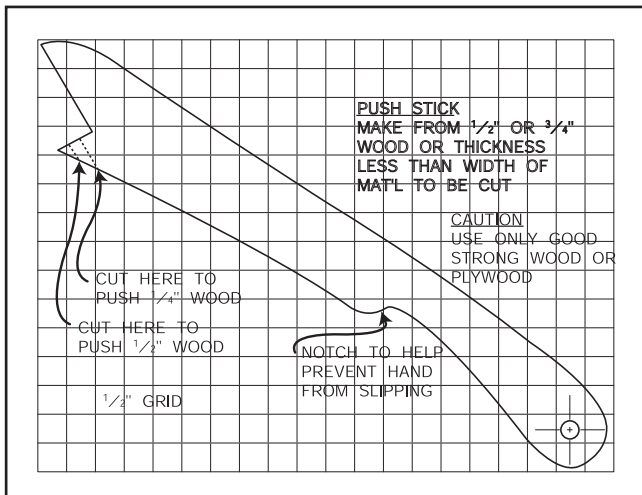

Figure 70. Shop made push stick.

Featherboard

Not only do featherboards make great anti-kickback devices, but they maintain pressure on the workpiece while cutting, which makes operation easier and safer because the cut can be completed without the operator's hands getting near the blade. When used together with push sticks, the overall risk of injury can be greatly reduced.

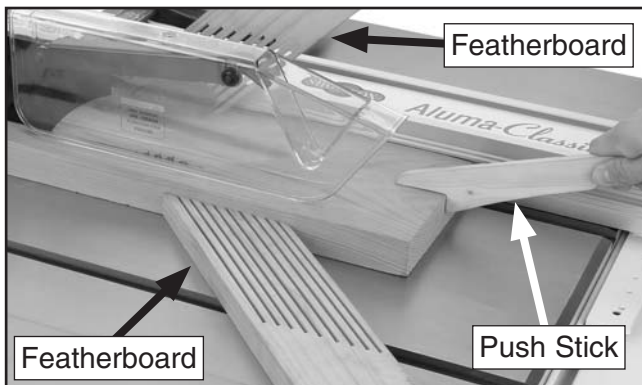

Figure 71. Examples of featherboards in use.

Outfeed & Support Tables

One of the best accessories for improving the safety and ease of using a table saw is simply placing a large table (outfeed table) behind the saw to catch the workpiece. Additionally, another table to the left of the saw (support table) can also help support large workpieces so they can be cut safely and accurately.



Figure 72. Example of outfeed & support tables.

Crosscut Sled

A crosscut sled is a fantastic way to improve the safety and accuracy of crosscutting on the table saw. Most expert table saw users use a crosscut sled when they have to crosscut a large volume of work, because the sled offers substantial protection against kickback.



Figure 73. Example of crosscut sled.



SECTION 6: MAINTENANCE



Schedule

For optimum performance from your machine, follow this maintenance schedule and refer to any specific instructions given in this section.

Daily Check:

- Inspect blades for damage or wear.
- Check for loose mounting bolts/arbor nut.
- Check cords, plugs, and switch for damage.
- Any other condition that could hamper the safe operation of this machine.
- Wipe the table clean after every use—this ensures moisture from wood dust does not remain on bare metal surfaces.

Weekly Maintenance:

- Wipe down the table surface and grooves with a lubricant and rust preventive such as SLIPIT®.
- Vacuum dust buildup from the motor housing and trunnions.
- Clean the pitch and resin from the saw blade with a cleaner like OxiSolv® Blade & Bit Cleaner.

Monthly Maintenance:

- Check/tighten the belt tension (**Page 54**).

Cleaning

Cleaning the Model G0661 is relatively easy. Vacuum excess wood chips and sawdust, and wipe off the remaining dust with a dry cloth. If any resin has built up, use a resin dissolving cleaner to remove it.

After cleaning, treat all unpainted cast iron and steel with a non-staining lubricant after cleaning. We recommend products like G96® Gun Treatment, SLIPIT®, or Boeshield® T-9 (see **Section 5: Accessories** on **Page 39** for more details).

Occasionally it will become necessary to clean the internal parts with more than a vacuum. To do this, remove the table top and clean the internal parts with resin/pitch dissolver or mineral spirits and a stiff wire brush or steel wool. **DO NOT USE WATER—WATER WILL CAUSE CAST IRON TO RUST.**

Make sure the internal workings are dry before using the saw again, so that wood dust will not accumulate. If any essential lubrication is removed during cleaning, re-lubricate those areas.



Lubrication

An essential step for lubrication is cleaning the components before lubricating them.

This idea is critical because dust and chips build up on lubricated components and make the components hard to move. Simply adding more grease to the components with built-up grime on them will not yield smooth moving components.

Clean the components in this section with an oil/grease soluble cleaner, such as shown on **Page 16** of this manual.

If you thoroughly clean the components in this section before lubricating them, the result will be silky smooth movement when turning the handwheels, which will result in much higher enjoyment on your part!

The following are the main components that need to be lubricated:

- Trunnion Slides and Tilt Leadscrew
- Bevel Gears, Elevation Leadscrew and Rails

Trunnion Slides & Tilt Leadscrew

The trunnion slides are simply the grooved portions of the trunnions where the cast iron components slide against each other as the blade is tilted (see **Figure 74**).

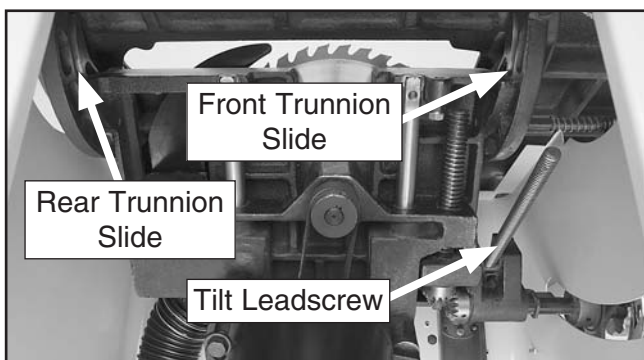

Figure 74. Trunnion slides and tilt leadscrew.

Clean the trunnion slides out with mineral spirits and brush a dollop of lithium grease into each groove, and around the leadscrew next to where it goes into the housing. Move the blade tilt back-and-forth to spread the grease.

Bevel Gears, Elevation Leadscrew and Rails

The bevel gears are shown below in **Figure 75**. When the blade height handwheel is rotated, the bevel gears turn the elevation leadscrew to raise/lower the motor housing assembly, using the elevation rails as rigid guides. In consideration of these mechanics, it is best to start the lubrication process with the blade completely lowered.

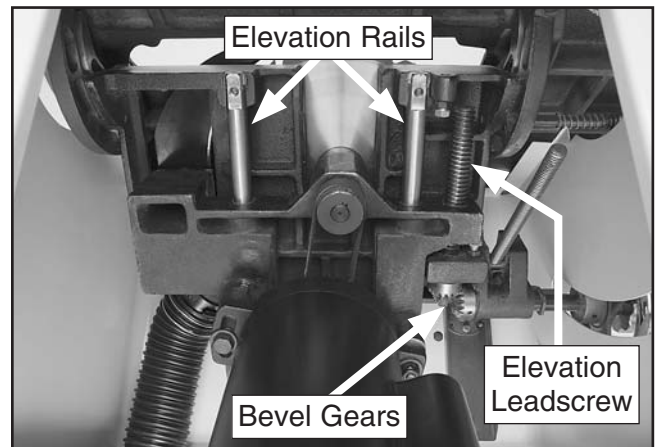

Figure 75. Bevel gears, elevation leadscrew and rails

Clean all the components in **Figure 75** with mineral spirits before lubricating.

Lubricate the bevel gears and elevation leadscrew with lithium grease. Brush a dollop into the bevel gear teeth and around the elevation leadscrew right next to where it goes into the housing.

Brush a small amount of grease (or oil) onto the elevation rails and wipe them down with a rag. The goal is to spread a thin film over the rails to mostly protect them from rust.



SECTION 7: SERVICE

Review the troubleshooting and procedures in this section to fix or adjust your machine if a problem develops. If you need replacement parts or you are unsure of your repair skills, then feel free to call our Technical Support at (570) 546-9663.

Troubleshooting

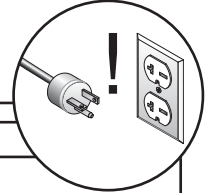

Symptom	Possible Cause	Possible Solution
Machine does not start or a breaker trips.	<ol style="list-style-type: none"> 1. OFF button not reset. 2. Power supply switched OFF or at fault. 3. Plug/receptacle at fault/wired wrong. 4. Motor connection wired wrong. 5. Start capacitor at fault. 6. Wiring open/has high resistance. 7. ON/OFF switch at fault. 8. Centrifugal switch at fault. 9. Motor at fault. 	<ol style="list-style-type: none"> 1. Press OFF button completely until it clicks. 2. Ensure power supply is on/has correct voltage. 3. Test for good contacts; correct the wiring. 4. Correct motor wiring connections. 5. Test/replace if faulty. 6. Check/fix broken, disconnected, or corroded wires. 7. Replace switch. 8. Adjust/replace centrifugal switch if available. 9. Test/repair/replace.
Machine stalls or is underpowered.	<ol style="list-style-type: none"> 1. Feed rate/cutting speed too fast. 2. Workpiece material unsuitable for machine. 3. Workpiece crooked; fence mis-adjusted. 4. Machine undersized for task. 5. Belt slipping. 6. Motor wired incorrectly. 7. Plug/receptacle at fault. 8. Run capacitor at fault. 9. Pulley/sprocket slipping on shaft. 10. Motor bearings at fault. 11. Motor overheated. 12. Motor at fault. 13. Centrifugal switch at fault. 	<ol style="list-style-type: none"> 1. Decrease feed rate/cutting speed. 2. Only cut wood/ensure moisture is below 20%. 3. Straighten or replace workpiece/adjust fence. 4. Use correct blade/reduce feed rate or depth of cut. 5. Tension/replace belt (Page 54). 6. Wire motor correctly. 7. Test for good contacts/correct wiring. 8. Test/repair/replace. 9. Replace loose pulley/shaft. 10. Test/repair/replace. 11. Clean motor, let cool, and reduce workload. 12. Test/repair/replace. 13. Adjust/replace centrifugal switch if available.
Machine has vibration or noisy operation.	<ol style="list-style-type: none"> 1. Motor or component loose. 2. Blade at fault. 3. Belt worn or loose. 4. Pulley loose. 5. Motor mount loose/broken. 6. Machine incorrectly mounted. 7. Arbor pulley loose. 8. Motor fan rubbing on fan cover. 9. Arbor bearings at fault. 10. Motor bearings at fault. 11. Centrifugal switch. 	<ol style="list-style-type: none"> 1. Inspect/replace damaged bolts/nuts, and re-tighten with thread locking fluid. 2. Replace warped/bent blade; sharpen dull blade. 3. Tension/replace belt (Page 54). 4. Realign/replace shaft, pulley, setscrew, and key. 5. Tighten/replace. 6. Tighten mounting bolts; relocate/shim machine. 7. Retighten/replace arbor pulley. 8. Fix/replace fan cover; replace loose/damaged fan. 9. Replace arbor housing bearings; replace arbor. 10. Test by rotating shaft; grinding/loose shaft requires bearing replacement. 11. Replace.



Symptom	Possible Cause	Possible Solution
Blade is not aligned with miter slot or fence.	<ol style="list-style-type: none"> 1. Blade is warped. 2. Table top is not parallel to blade. 3. Fence is not parallel to blade. 	<ol style="list-style-type: none"> 1. Replace blade (Page 25). 2. Make table parallel to blade (Page 48). 3. Make fence parallel to blade (Page 51).
Blade does not reach 90°.	<ol style="list-style-type: none"> 1. 90° stop bolt is out of adjustment. 2. Sawdust stuck on stop bolt. 	<ol style="list-style-type: none"> 1. Adjust 90° stop bolt (Page 47). 2. Clean sawdust off stop bolt.
Blade hits insert at 45°.	<ol style="list-style-type: none"> 1. 45° stop bolt is out of adjustment. 2. Sawdust stuck on stop bolt. 3. Hole in insert is inadequate. 4. Table out of alignment. 5. Blade position is incorrect. 	<ol style="list-style-type: none"> 1. Adjust 45° stop bolt (Page 47). 2. Clean sawdust off stop bolt. 3. File or mill the hole in the insert. 4. Align blade to the table (Page 48). 5. Adjust blade position.
Board binds or burns when feeding through table saw.	<ol style="list-style-type: none"> 1. Dull blade. 2. Blade is warped. 3. Fence is not parallel to blade. 4. Table top is not parallel to blade. 	<ol style="list-style-type: none"> 1. Replace blade. 2. Replace blade (Page 25). 3. Make fence parallel to blade (Page 51). 4. Make table parallel to blade (Page 48).



Blade Tilt Stops

The table saw features set screws that stop the blade exactly at 45° and 90° when tilting it with the handwheel. The stops have been set at the factory and should require no adjustments, unless you notice that your cuts are not accurate.

If you do need to adjust the blade tilt stops, you can access the set screws from the top of the table, in the holes shown in **Figure 76**.

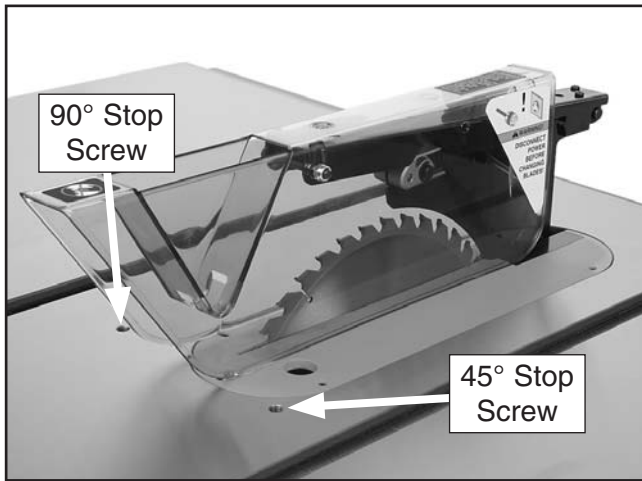

Figure 76. 90° stop bolt and jam nut.

Note: The tilt scale reads "0" when the blade is 90° to the table.

Tools Needed	Qty
90° Square	1
45° Square	1
Hex Wrench 4mm.....	1
Phillips Screwdriver	1

Setting 90° Stop Bolt

1. DISCONNECT THE SAW FROM POWER!
2. Raise the blade as high as it will go, then tilt it toward 0° until it stops and cannot be tilted any more.
3. Place a 90° square against the table and blade so it contacts the blade evenly from bottom to top, as shown in **Figure 77**. Make sure a blade tooth does not obstruct the placement of the square.

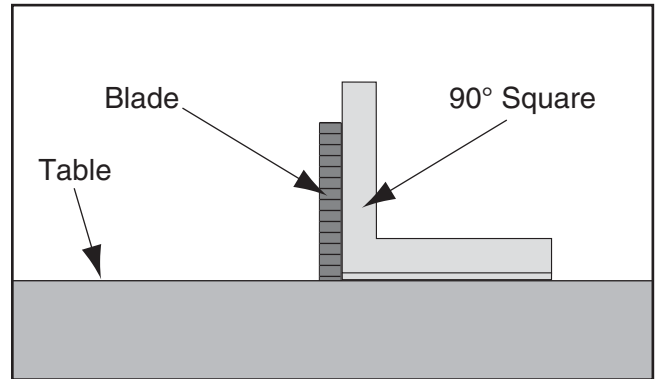

Figure 77. Checking blade at 90°.

—If the blade is 90° to the table, then adjustments do not need to be made. Make sure the tilt indicator arrow shown in **Figure 78** points to the 0° mark on the scale. Adjust the position by loosening the screw, moving the indicator with your fingers, then tightening the screw.

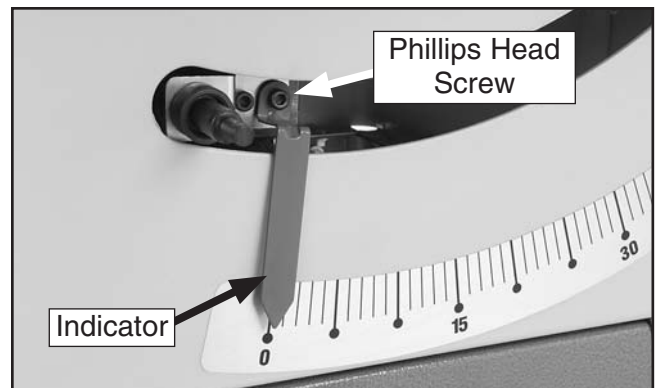

Figure 78. Tilt indicator arrow.

—If the blade is not 90° to the table, you will need to adjust the 90° stop screw. Proceed to the next step.

4. Tilt the blade away from 0° by about 5°, so there is room for the set screw to move.
5. Adjust the 90° set screw according to how far off the blade was from 90°, then recheck the blade and repeat the adjustment as necessary until the blade stops at 90°.



Setting 45° Stop Bolt

1. DISCONNECT THE SAW FROM POWER!
2. Raise the blade as high as it will go, then tilt it towards 45° until it stops and cannot be tilted any more.
3. Place a 45° square against the table and blade so it contacts the blade evenly from bottom to top, as shown in **Figure 79**. Make sure a blade tooth does not obstruct the placement of the square.

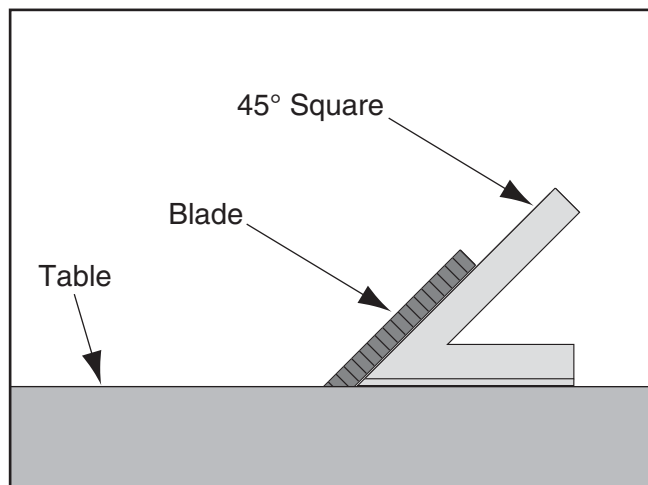

Figure 79. Checking blade at 45°.

—If the blade is 45° to the table, then adjustments do not need to be made.

—If the blade is not 45° to the table, you will need to adjust the 45° stop screw. Proceed to the next step.

4. Tilt the blade away from 45° by about 5°, so there is room for the set screw to move.
5. Adjust the 45° set screw according to how far off the blade was from 45°, then recheck the blade and repeat the adjustment as necessary until the blade stops at 45°.

Miter Slot to Blade Parallelism

Tools Needed

	Qty
Adjustable Square	1
Metal Shim Stock	As Needed
Marker	1

Your table saw will give the best results if the miter slot and the rip fence are adjusted parallel to the blade. If either of these are not exactly parallel, your cuts and your finished work will be lower in quality, but more importantly, the risk of kickback will be increased. Take the time to adjust your table saw properly. A few minutes now will be time well spent.

To adjust the blade parallel to the miter slot:

1. DISCONNECT THE SAW FROM POWER!
2. Use an adjustable square to measure the distance from the miter slot to a carbide tip on the blade, as shown in **Figure 80**. Make sure that the face of the adjustable square is even along the miter slot.

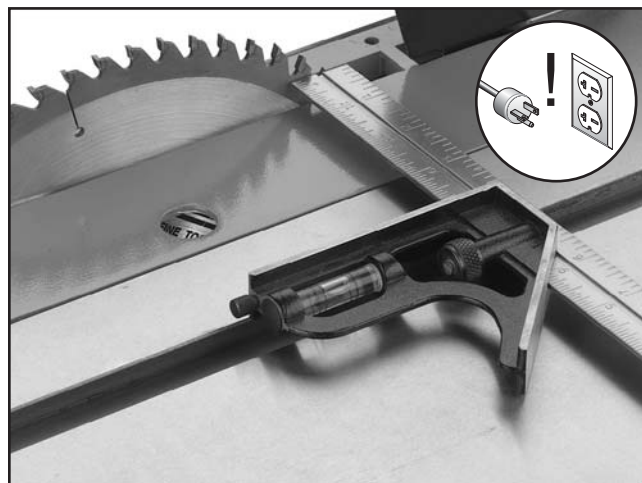

Figure 80. Example of adjusting blade to miter slot.



- With the end of the adjustable square just touching the tip, lock the square in place. Now, mark the carbide tip with a marker where you made this measurement.

⚠ CAUTION

The saw blade is dangerously sharp. Use extra care or wear gloves when handling the blade or working near it.

- Rotate the marked blade tip to the other end of the table insert.
- Slide the adjustable square down to the other end of the table insert, and compare the distance from the marked blade tip to the end of the adjustable square.
 - If the blade tip does not touch the end of the adjustable square similar to the first measurement, the table will need to be adjusted. Proceed to **Step 6**.
 - If the blade tip measurement is the same on both sides, go to **Step 7**.
- To adjust the table, loosen the hex bolts in the table mounting locations (see **Figure 81**) and slightly tap the table in the needed direction. Repeat **Steps 2–5** until the blade and miter slot are parallel.
- Tighten the table mounting bolts in a criss-cross, alternating manner.

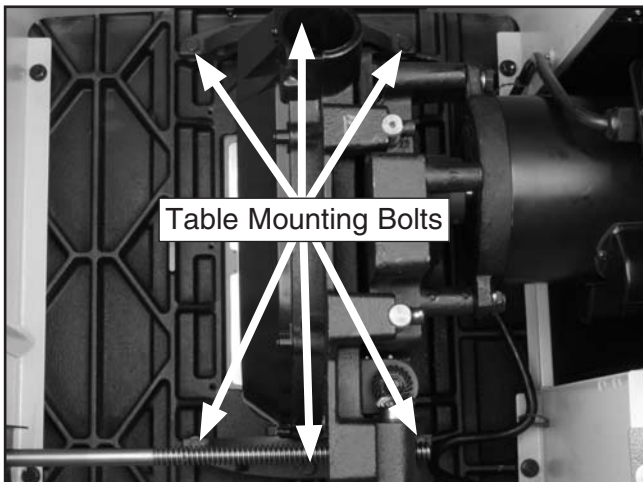

Figure 81. Table mounting bolts.

Splitter or Riving Knife Alignment

Spreader Thickness	Size
Splitter	0.092"
Riving Knife	0.092"

Checking Splitter/Riving Knife Alignment

The blade guard splitter and riving knife must be aligned with the blade when installed. If the splitter/riving knife is not aligned with the blade, then the workpiece will be forced sideways during the cut, which will increase the risk of kickback.

Tools Needed	Qty
Straightedge	1

To check the splitter/riving knife alignment:

- DISCONNECT THE SAW FROM POWER!
- Raise the saw blade to the maximum height so you have easy working access.
- Place the straightedge against the blade and the splitter/riving knife. When properly aligned, the splitter/riving knife will be in the "Alignment Zone", shown in **Figure 82**, and will be parallel with the blade.

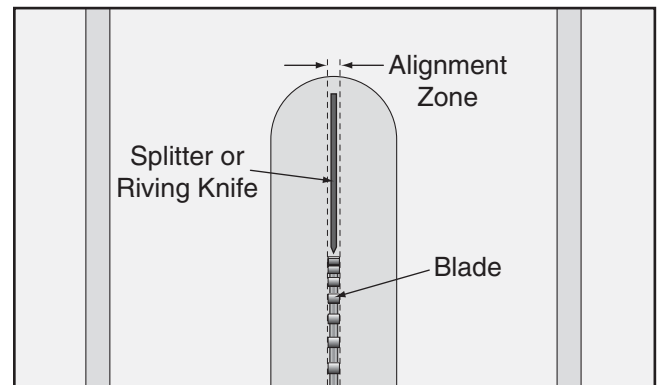

Figure 82. Splitter/riving knife alignment zone.



—If the splitter/riving knife is not inside the alignment zone, then it needs to be shimmed. Proceed to **Shimming Splitter/Riving Knife** instructions.

—If the splitter/riving knife is not parallel with the blade, then it needs to be straightened. Proceed to **Straightening Splitter/Riving Knife** instructions.

3. Check the alignment as you did previously.

—If the splitter/riving knife is in the alignment zone, not additional steps are necessary.

—If the splitter/riving knife is still not aligned with the blade, add or remove shims as necessary to correctly position the splitter/riving knife.

Shimming Splitter/Riving Knife

The splitter/riving knife mounting position can be adjusted into alignment with the blade with metal shims.

Note: These instructions require that you complete the **Checking Splitter/Riving Knife Alignment** instructions first and that the saw is disconnected from power and the blade is raised.

Possible Tools Needed	Qty
Arbor Wrenches	2
Metal Shims.....	As Needed
Hex Wrench 6mm.....	1
Phillips Screwdriver #2.....	2

To shim the splitter/riving knife:

1. Remove the splitter/riving knife by loosening the mounting bolt with the arbor wrench.

Note: Do not fully remove the mounting bolt because the shims you place in the next step will straddle the threads of the mounting bolt.

2. Place three shims inside the mounting block, as in **Figure 83**, then reinstall the splitter/riving knife, and fully tighten the mounting bolt.

Note: Sometimes the splitter/riving knife will not align with the blade when using the maximum amount of shims (six) that will fit. If this is the case, then remove the mounting block and place shims behind it, as shown in **Figure 84**.

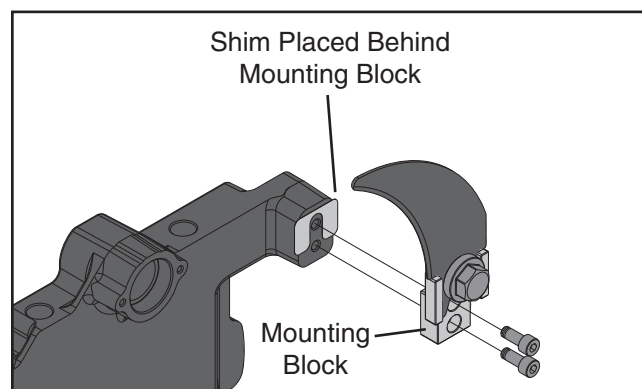

Figure 84. Shimming outside the block.

Straightening Splitter/Riving Knife

If the splitter or riving knife is not parallel to the blade, it is possible that it is bent.

To fix this, bend it by hand (while installed) until it is aligned with the blade. If this doesn't work, remove it to straighten. If you cannot straighten it properly, just replace it.

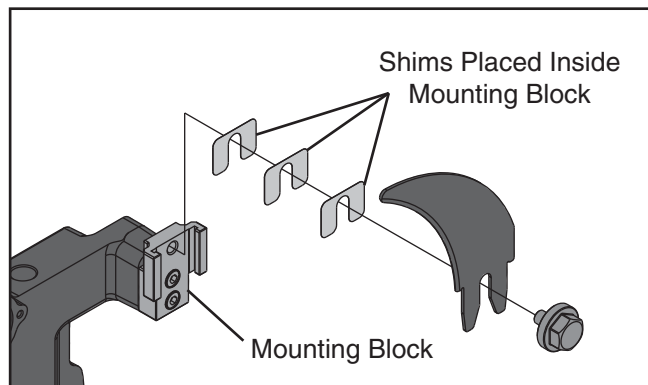

Figure 83. Shimming inside the block.



Fence Adjustments

There are four main adjustments for the fence: square, height, parallelism, and clamping pressure. Keep in mind that these adjustments are interconnected and some trial-and-error may be needed to achieve satisfactory results.

Tools Needed	Qty
Hex Wrench 4mm.....	1
Hex Wrench 6mm.....	1
Square.....	1
Felt-Tipped Marker.....	1

Square and Height

The fence face must be square to the table in order to produce square cuts. Also, the fence should be adjusted high enough off the table that it does not drag across the surface.

To check/adjust the fence height and squareness to the table:

1. DISCONNECT THE SAW FROM POWER!
2. Place a square on the table against the face of the fence (**Figure 85**) to check if the fence is square to the table.
 - If the fence is not square to the table, proceed to **Step 3**.
 - If the fence is square to the table, skip ahead to **Step 4**.

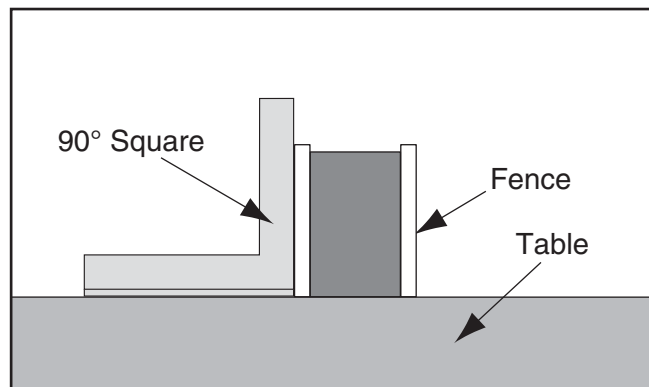

Figure 85. Checking if fence is square to table.

3. Adjust the set screws (**Figure 86**) on top of the fence bracket to ensure the fence face is 90° to the table.

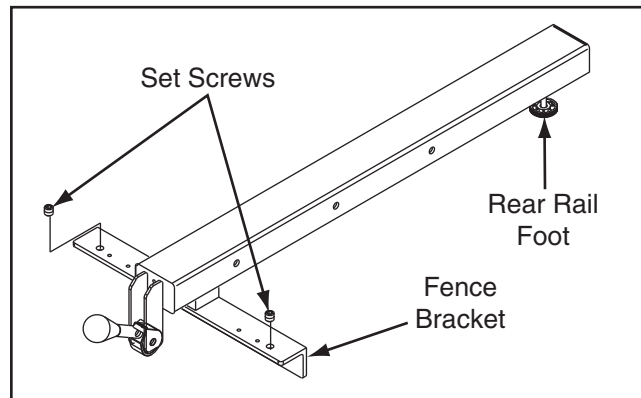

Figure 86. Fence components used to adjust fence height and squareness to table.

4. Look at the gap between the fence and the table top.
 - If the gap is approximately 1/16" and even from the front of the table to the back, then no additional adjustments are necessary.
 - If the gap is uneven, if the fence height is more than 1/8", or if the fence touches the table, then continue with **Step 5**.
5. Adjust the fence height with the rear rail foot until the gap between the table and the fence is approximately 1/16" and even from the front of the table to the back.

Note: If the front end of the fence needs to be adjusted up or down, use the set screws from **Figure 86**; however, turn them in even increments and recheck the squareness afterwards.



Clamping Pressure and Parallelism

The fence clamping mechanism adjusts the clamping pressure to hold your fence securely and position the fence parallel to the blade.

To adjust the fence clamping pressure and parallelism to the blade:

1. DISCONNECT THE SAW FROM POWER!
2. Remove the fence and adjust the set screws shown in **Figure 87** equally on the rear side of the front bracket as necessary until the clamping pressure is strong enough that the fence will not move as pressure is applied against it.

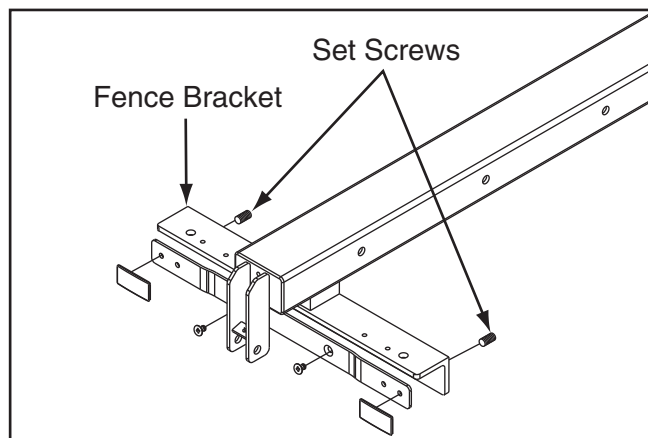

Figure 87. Location of set screws used to adjust fence parallelism and clamping pressure.

3. Place the fence approximately 4" away from the blade.
4. Measure the distance between the fence and the front of the blade, then mark the tooth that you measured from with a felt-tipped marker.

5. Rotate the blade 180° (**Figure 88**), and recheck the distance between the fence and the blade to ensure they are parallel.

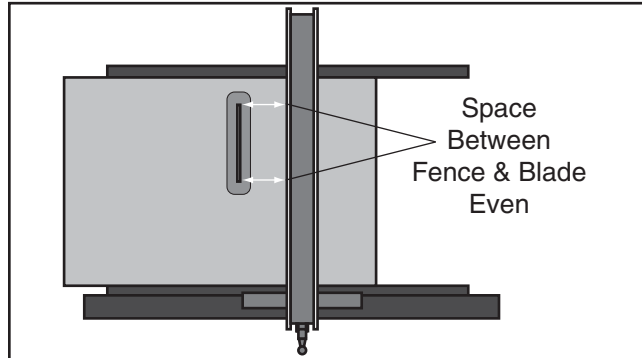

Figure 88. Example of fence aligned parallel to miter slot.

6. Use trial-and-error to adjust the set screws so the fence is parallel to the blade and the clamping pressure is sufficient.

Optional: Some woodworkers prefer to offset the rear of the fence $\frac{1}{64}$ " from the blade, as shown in **Figure 89**, to help prevent the workpiece from binding and burning.

The argument is that this offset adjustment reduces the chance of kickback by alleviating potential binding that may occur between the backside of the blade and fence. The trade-off is slightly less accurate cuts.

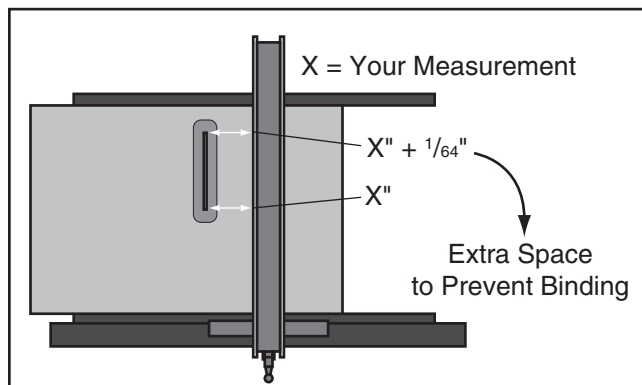

Figure 89. Adjusting fence with a $\frac{1}{64}$ " offset.



Fence Scale Calibration

The fence scale indicator windows, shown in **Figure 90**, can be calibrated with the fence scale if you notice that your cuts do not accurately match what is shown on the fence scale. The indicator window on the right side is used when the fence is positioned on the right side of the blade. The indicator window on the left side is used when the fence is positioned on the left side of the blade.

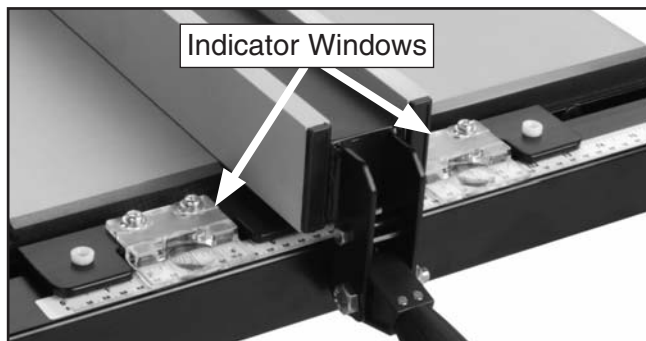

Figure 90. Fence indicator windows.

The indicator adjusts by loosening the two mounting screws and sliding it in the desired direction. Repeat this procedure for both windows.

Tools Needed	Qty
Phillips Head Screwdriver	1
Scrap Piece of Wood	1

To calibrate the fence scale indicator windows:

1. Position and lock the fence at 13", as indicated by the scale, cut your scrap piece of wood.
2. Reposition and lock the fence at 12", as indicated by the scale.
3. Flip your scrap piece of wood over, placing the side that was cut in **Step 2** against the fence, and cut your scrap piece of wood.
4. Measure the width of the freshly cut workpiece with a tape measure. The workpiece width should be exactly 12". If it is not, then adjust the indicator window to match the width of the workpiece.

Miter Gauge Adjustments

The miter gauge is equipped with stop screws that allow you to easily adjust the miter gauge from 45° to the left, 90°, and 45° to the right. The stop screws contact the shaft, which moves in or out of the way for adjustments.

Tools Needed	Qty
Hex Wrench 2.5mm.....	1
Phillips Head Screwdriver	1
90° Square	1
45° Square	1
Wrench 8mm	1

Checking/Setting 90° Stops

1. DISCONNECT THE SAW FROM POWER!
2. Slide the miter gauge into the T-slot on the table.
3. Adjust the miter gauge so the 90° stop screw rests against the sliding shaft.
4. Place the square evenly against the face of the miter gauge and the blade, as shown in **Figure 91**.

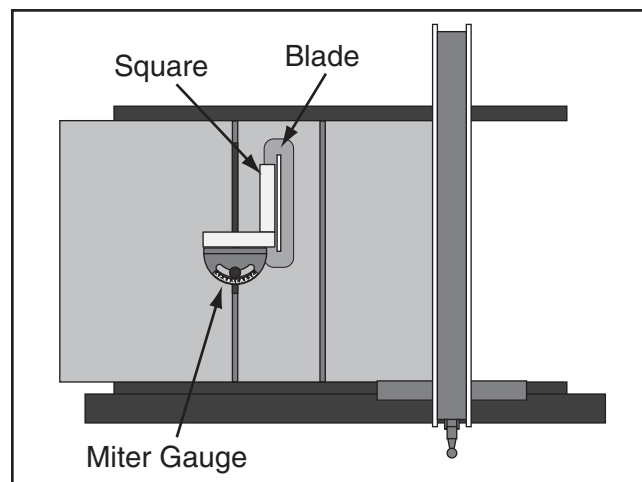

Figure 91. Checking 90° stop on miter gauge.



—If the square touches the miter body and the body of the blade (not the teeth) evenly at the same time, then it is square to the blade and the 90° stop is set correctly. No further adjustments are necessary.

—If the square does not touch the miter body and blade body evenly at the same time, then proceed to **Step 4**.

5. Loosen the hex nut (jam nut) that secures the 90° stop screw and adjust the stop screw until it is seated against the shaft while the square is evenly touching the miter body and the blade body, then tighten the hex nut.
6. Loosen the screw on the front of the miter bar, adjust the pointer to 0°, then tighten the screw.

Checking/Setting 45° Stops

Follow the same process with the 45° stops that you followed with the 90°, except using a 45° square or adjustable square to verify that the miter body is 45° to the blade, as shown in **Figure 92**.

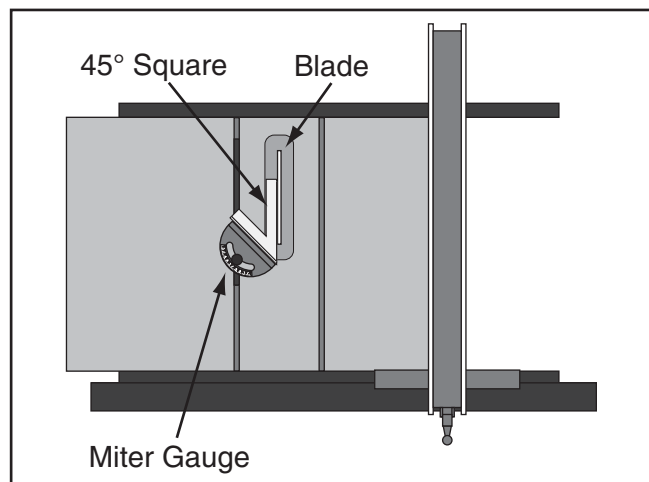

Figure 92. Checking 45° stop on miter gauge.

Belt Tension & Replacement

The belt stretches slightly as the saw is used. Most of the belt stretching will happen during the first 16 hours of use, but it may continue in small increments through continued use.

Tools Needed	Qty
Wrench or Socket 17mm.....	1

Tensioning Belt

1. DISCONNECT THE SAW FROM POWER!
2. Loosen the hex bolt and hex nut shown in **Figure 93**, and pivot the motor up and down to make sure that it is movable.

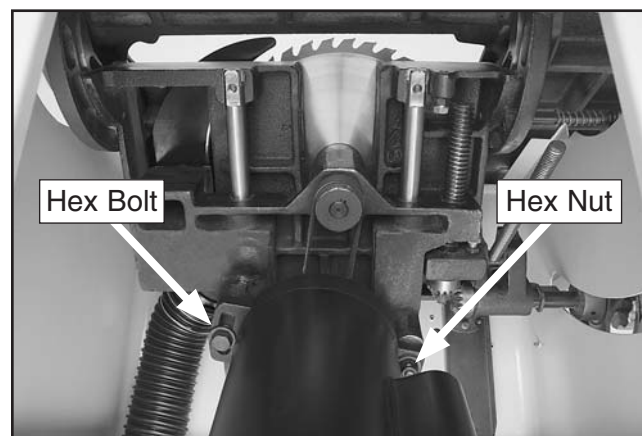

Figure 93. Motor mounting fasteners.

3. Press down on the motor with one hand to keep the belt tension tight, and tighten the hex bolt with the other hand.
4. Tighten the hex nut.

Replacing Belt

1. DISCONNECT THE SAW FROM POWER!
2. Remove the motor mount hex bolt and loosen, but do not remove, the motor mount hex nut shown in **Figure 93**.
3. Pivot the motor up and remove the belt from the arbor pulley.
4. Pivot the motor down and remove the belt completely.
5. Install the new belt in the reverse manner that you removed the old one, and allow the weight of the motor to tension the belt.
6. Press down on the motor with one hand to keep the belt tension tight, and install and tighten the hex bolt with the other hand.
7. Tighten the hex nut.



SECTION 8: WIRING

These pages are current at the time of printing. However, in the spirit of improvement, we may make changes to the electrical systems of future machines. Study this section carefully. If there are differences between your machine and what is shown in this section, call Technical Support at (570) 546-9663 for assistance BEFORE making any changes to the wiring on your machine.

WARNING















Wiring Safety Instructions

1. **SHOCK HAZARD.** Working on wiring that is connected to a power source is extremely dangerous. Touching electrified parts will result in personal injury including but not limited to severe burns, electrocution, or death. Disconnect the power from the machine before servicing electrical components!
2. **QUALIFIED ELECTRICIAN.** Due to the inherent hazards with electricity, only a qualified electrician should perform wiring tasks on this machine. If you are not a qualified electrician, get help from one before attempting any kind of wiring job.
3. **WIRE CONNECTIONS.** All connections must be tight to prevent wires from loosening during machine operation. Double-check all wires disconnected or connected during any wiring task to ensure tight connections.
4. **MOTOR WIRING.** The motor wiring shown in these diagrams are current at the time of printing, but it may not match your machine. Always use the wiring diagram inside the motor junction box.
5. **MODIFICATIONS.** Using non-OEM parts or modifying the wiring beyond what is shown in the diagram may lead to unpredictable results, including serious injury or fire.
6. **WIRE/COMPONENT DAMAGE.** Damaged wires or components increase the risk of serious personal injury, fire, or machine damage. If you notice that any wires or components are damaged while performing a wiring task, replace those wires or components before completing the task.
7. **CAPACITORS.** Some capacitors store an electrical charge for up to five minutes after being disconnected from the power source. Before doing any work on capacitors, wait at least this long to avoid being shocked.
8. **CIRCUIT REQUIREMENTS.** You MUST follow the requirements **Page 12** when connecting your machine to a power source.
9. **EXPERIENCING DIFFICULTIES.** If you are experiencing difficulties understanding the information included in this section, contact our Technical Support at (570) 546-9663.

NOTICE

The photos and diagrams included in this section are best viewed in color. You can view these pages in color at www.grizzly.com.

COLOR KEY

BLACK 	BLUE 	YELLOW 	LIGHT BLUE 
WHITE 	BROWN 	YELLOW GREEN 	BLUE WHITE 
GREEN 	GRAY 	PURPLE 	TURQUOISE 
RED 	ORANGE 	PINK 	



Wiring Diagram

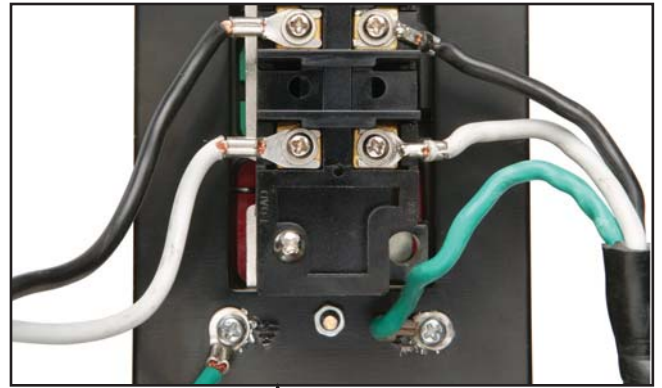

MOTOR (Prewired 110V)

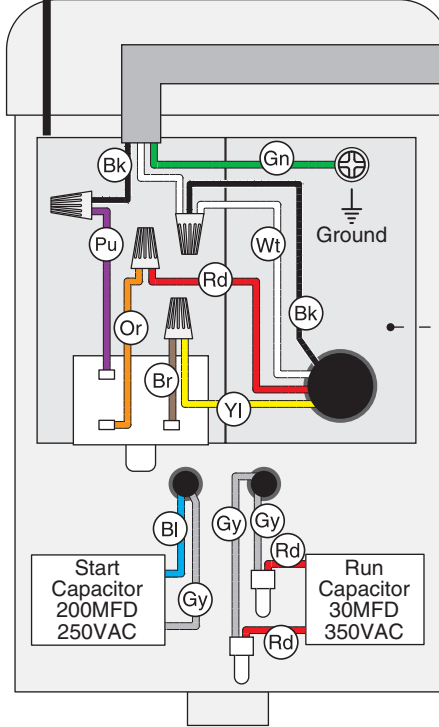

**PUSH BUTTON SWITCH
(viewed from behind)**

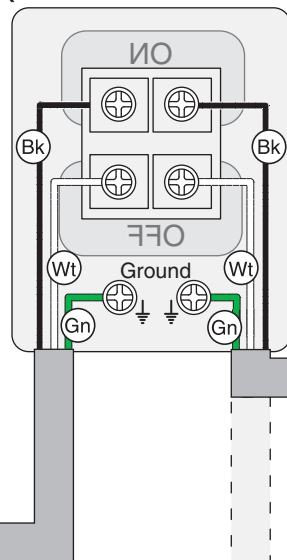

**5-15 PLUG
(Included)**

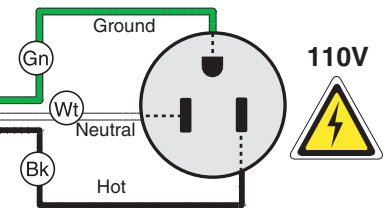

110V

**6-15 PLUG
(As Recommended)**



220V

**MOTOR
(Wired 220V)**

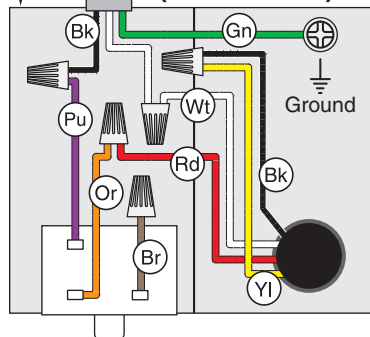

⚠ DANGER
Disconnect power before performing any electrical service. Electricity presents serious shock hazards that will result in severe personal injury and even death!

NOTICE
The motor wiring shown here is current at the time of printing; however, always use the diagram on the inside of junction box cover when rewiring your motor.



SECTION 9: PARTS

Table Saw Body Breakdown

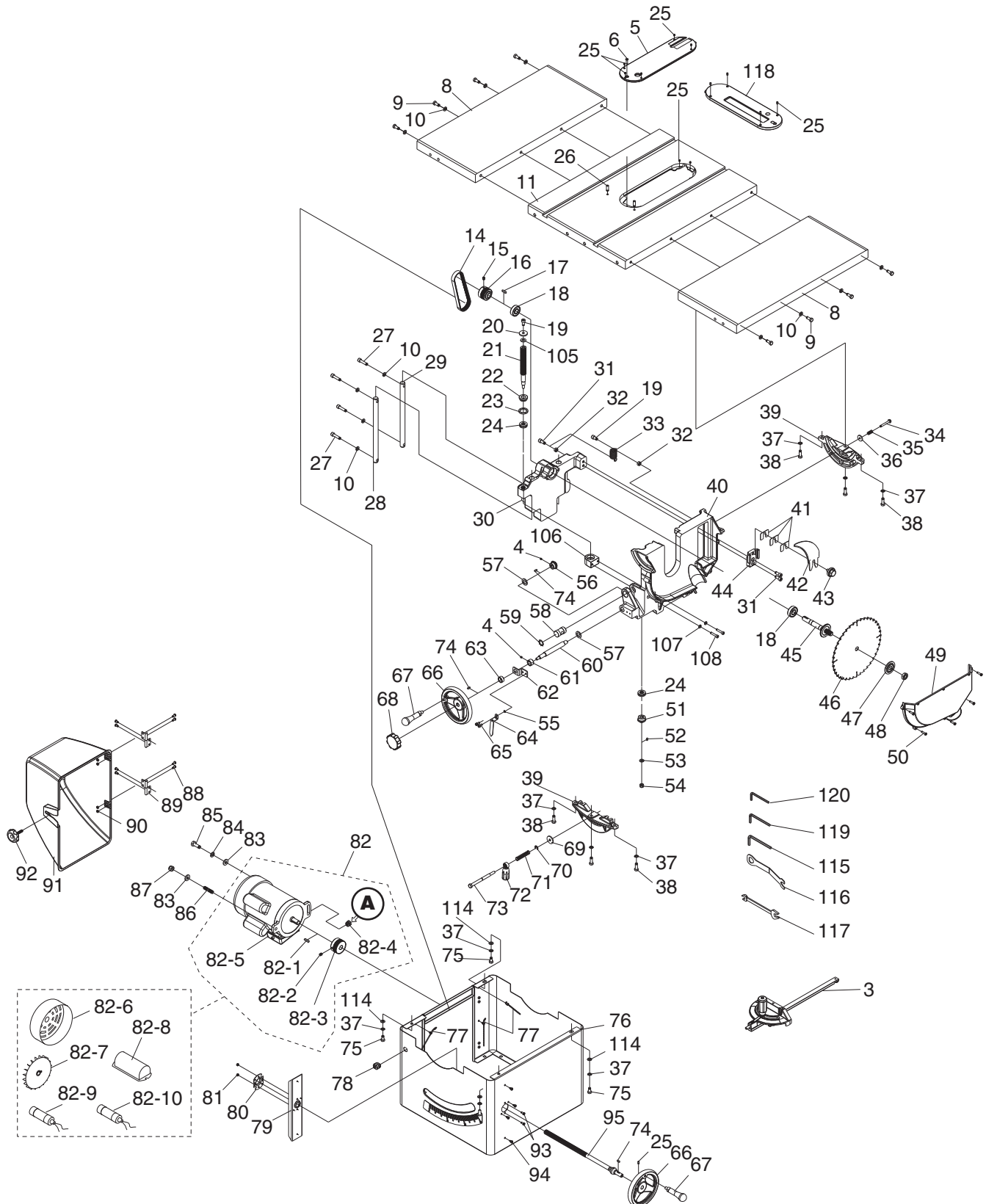

Table Saw Body Parts List

REF	PART #	DESCRIPTION
3	P0661003	MITER GAUGE ASSEMBLY
4	PSS07M	SET SCREW M5-.8 X 5
5	P0661005	TABLE INSERT
6	PFH54M	FLAT HD SCR M5-.8 X 20
8	P0661008	EXTENSION TABLE
9	PB09M	HEX BOLT M8-1.25 X 20
10	PLW04M	LOCK WASHER 8MM
11	P0661011	TABLE
14	P0661014	RIBBED BELT 170 J6
15	PSS20M	SET SCREW M8-1.25 X 8
16	P0661016	SPINDLE PULLEY
17	PK34M	KEY 5 X 5 X 20
18	P6203-2NSE	BALL BEARING 6203-2NSE
19	PSB11M	CAP SCREW M8-1.25 X 16
20	P0661020	SPECIAL WASHER 8MM
21	P0661021	LEADSCREW
22	P0661022	BUSHING
23	P0661023	GASKET
24	P51102	THRUST BEARING 51102
25	PSS31M	SET SCREW M5-.8 X 8
26	PSS09M	SET SCREW M8-1.25 X 20
27	PSB40M	CAP SCREW M8-1.25 X 35
28	P0661028	FRONT COLUMN
29	P0661029	REAR COLUMN
30	P0661030	BRACKET
31	PSB14M	CAP SCREW M8-1.25 X 20
32	PN03M	HEX NUT M8-1.25
33	P0661033	EXTENSION SPRING
34	PFB28M	FLANGE BOLT M6-1 X 40
35	P0661035	COMPRESSION SPRING
36	PW03M	FLAT WASHER 6MM
37	PTLW07M	EXT TOOTH WASHER 8MM
38	PB07M	HEX BOLT M8-1.25 X 25
39	P0661039	TRUNNION BRACKET
40	P0661040	TRUNNION
41	P0661041	SHIM
42	P0661042	RIVING KNIFE
43	P0661043	RIVING KNIFE/GUARD BOLT
44	P0661044	BRACKET
45	P0661045	SPINDLE
46	P0661046	BLADE 10" X 40T
47	P0661047	BLADE MOUNTING FLANGE
48	P0661048	ARBOR NUT 5/8"-12
49	P0661049	BLADE COVER
50	PS75M	PHLP HD SCR M5-.8 X 35
51	P0661051	BEVEL GEAR (LEFT)
52	PK05M	KEY 4 X 4 X 10
53	PW01M	FLAT WASHER 8MM
54	PLN04M	LOCK NUT M8-1.25
55	PTLW02M	EXT TOOTH WASHER 5MM
56	P0661056	BEVEL GEAR (RIGHT)
57	PW08M	FLAT WASHER 16MM
58	P0661058	SHAFT
59	P0661059	COUNTERSUNK EXT WASHER
60	P0661060	SHAFT
61	P0661061	COLLAR

REF	PART #	DESCRIPTION
62	P0661062	SUPPORT PLATE
63	P0661063	COLLAR
64	P0661064	POINTER
65	PFS07M	FLANGE SCREW M5-.8 X 10
66	P0661066	HANDWHEEL
67	P0661067	KNOB 3/8-16
68	P0661068	LOCKING KNOB 5/16-18
69	PW01M	FLAT WASHER 8MM
70	PEC015M	E-CLIP 8MM
71	P0661071	COMPRESSION SPRING
72	P0661072	HANDLE W/BUSHING
73	P0661073	SHAFT
74	PK69M	KEY 4 X 4 X 12
75	PB03M	HEX BOLT M8-1.25 X 16
76	P0661076	CABINET
77	P0661077	REUSABLE BEADED CABLE TIE
78	P0661078	STRAIN RELIEF SB8R-3
79	P0661079	PLATE
80	P0661080	BRACKET
81	PLN02M	LOCK NUT M5-.8
82	P0661082	MOTOR 2HP 110/220V 1-PH
82-1	PK34M	KEY 5 X 5 X 20
82-2	PSS20M	SET SCREW M8-1.25 X 8
82-3	P0661082-3	MOTOR PULLEY
82-4	P0661082-4	STRAIN RELIEF
82-5	P0661082-5	JUNCTION BOX
82-6	P0661082-6	MOTOR FAN COVER
82-7	P0661082-7	MOTOR FAN
82-8	P0661082-8	CAPACITOR COVER
82-9	P0661082-9	S CAPACITOR 200M 250V 1.5" x 2.75"
82-10	P0661082-10	R CAPACITOR 30M 350V 1.5" x 2.75"
83	PW04M	FLAT WASHER 10MM
84	PLW06M	LOCK WASHER 10MM
85	PB01M	HEX BOLT M10-1.5 X 30
86	P0661086	SHAFT
87	PLN05M	LOCK NUT M10-1.5
88	PS09M	PHLP HD SCR M5-.8 X 10
89	P0661089	HINGE
90	PN06M	HEX NUT M5-.8
91	P0661091	COVER
92	P0661092	KNOB BOLT M8-1.25 X 30
93	PS08M	PHLP HD SCR M5-.8 X 12
94	PHTEK37M	TAP SCREW M5 X 12
95	P0661095	LEADSCREW
105	P0661105	FLAT WASHER 9MM
106	P0661106	LEADSCREW NUT
107	PLW03M	LOCK WASHER 6MM
108	PSB07M	CAP SCREW M6-1 X 30
114	PW01M	FLAT WASHER 8MM
115	PAW06M	HEX WRENCH 6MM
116	P0661116	ARBOR WRENCH
117	PWR1113	WRENCH 11/13
118	P0661118	DADO TABLE INSERT
119	PAW05M	HEX WRENCH 5MM
120	PAW02.5M	HEX WRENCH 2.5MM



Stand Parts Breakdown

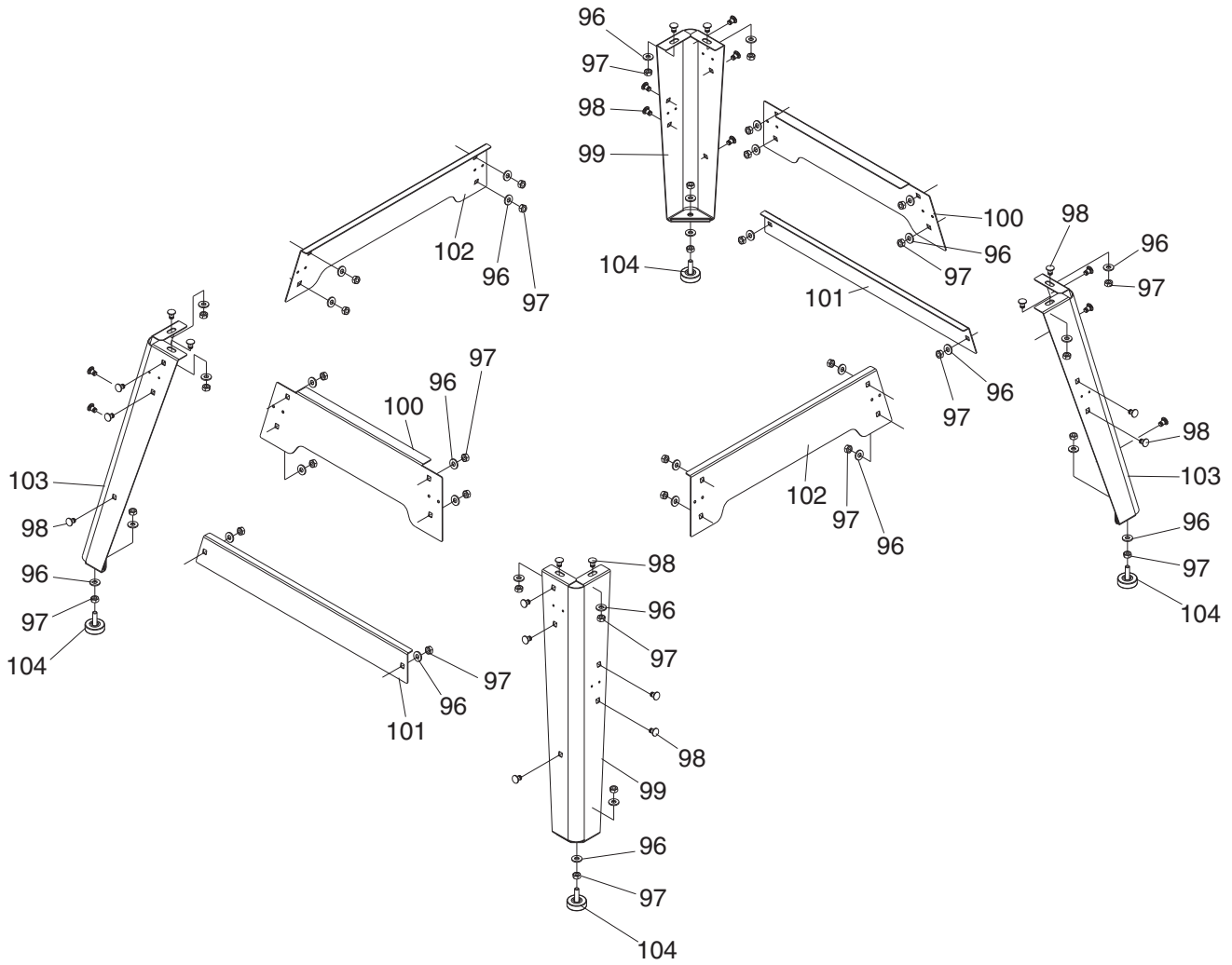

REF	PART #	DESCRIPTION
96	PW01M	FLAT WASHER 8MM
97	PN03M	HEX NUT M8-1.25
98	PCB11M	CARRIAGE BOLT M8-1.25 X 12
99	P0661099	RIGHT STAND LEG
100	P0661100	UPPER STAND BRACE

REF	PART #	DESCRIPTION
101	P0661101	LOWER STAND BRACE
102	P0661102	SIDE STAND BRACE
103	P0661103	LEFT STAND LEG
104	P0661104	FOOT



Guard & Switch Breakdown

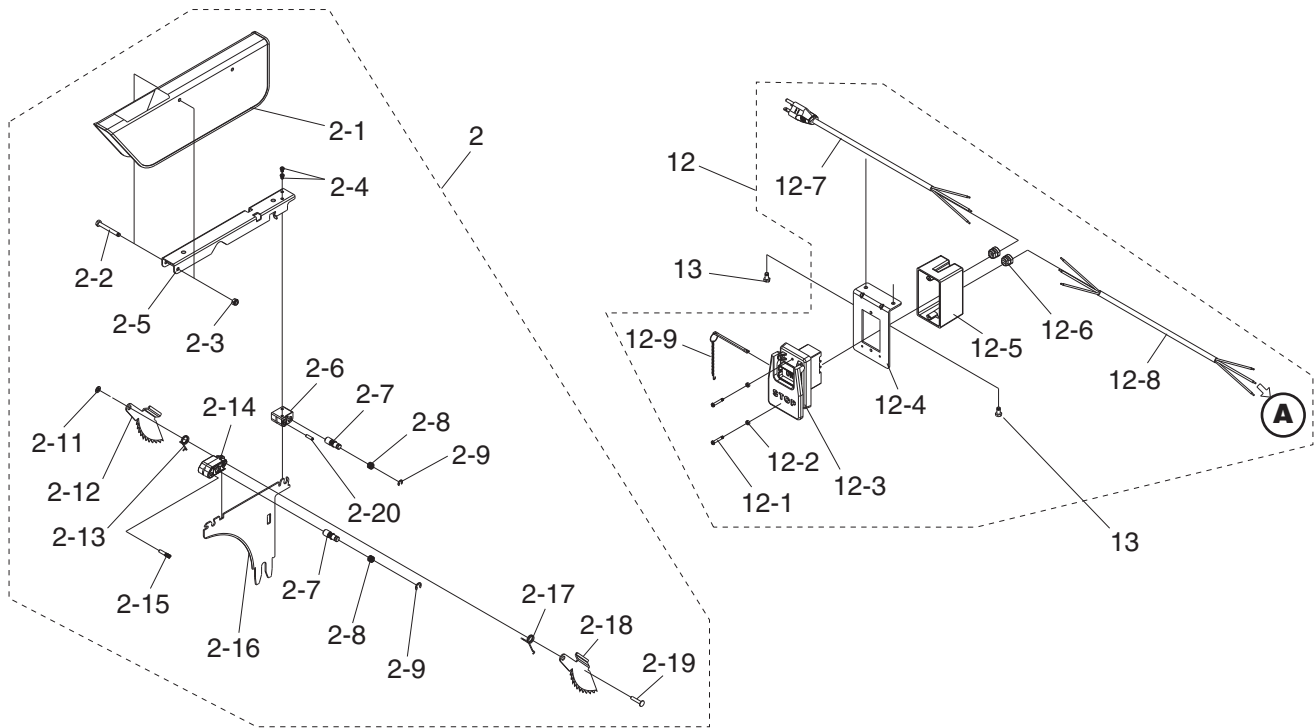

REF	PART #	DESCRIPTION
2	P0661002	BLADE GUARD ASSEMBLY
2-1	P0661002-1	BLADE GUARD
2-2	PB39M	HEX BOLT M6-1 X 50
2-3	PLN03M	LOCK NUT M6-1
2-4	PS17M	PHLP HD SCR M4-.7 X 6
2-5	P0661002-5	ROD
2-6	P0661002-6	BRACKET
2-7	P0661002-7	SHAFT
2-8	P0661002-8	COMPRESSION SPRING
2-9	PEC07M	E-CLIP 7MM
2-11	P0661002-11	PUSH NUT 4MM
2-12	P0661002-12	LEFT ANTI BACK PAWL
2-13	P0661002-13	SPRING (RIGHT)
2-14	P0661002-14	BRACKET
2-15	P0661002-15	PIN
2-16	P0661002-16	SPLITTER

REF	PART #	DESCRIPTION
2-17	P0661002-17	SPRING (LEFT)
2-18	P0661002-18	RIGHT ANTI BACK PAWL
2-19	P0661002-19	SHAFT
2-20	PRP76M	ROLL PIN 4 X 16
12	P0661012	COMPLETE SWITCH ASSEMBLY
12-1	PS18M	PHLP HD SCR M4-.7 X 25
12-2	PLW02M	LOCK WASHER 4MM
12-3	P0661012-3	SWITCH
12-4	P0661012-4	SWITCH BRACKET
12-5	P0661012-5	SWITCH BOX
12-6	PSW04-4	STRAIN RELIEF
12-7	P0661012-7	POWER CORD 12AWG X 10'
12-8	P0661012-8	MOTOR CORD 12AWG X 4'
12-9	P0661012-9	SWITCH DISABLING PIN
13	PB02M	HEX BOLT M6-1 X 12



Fence Breakdown

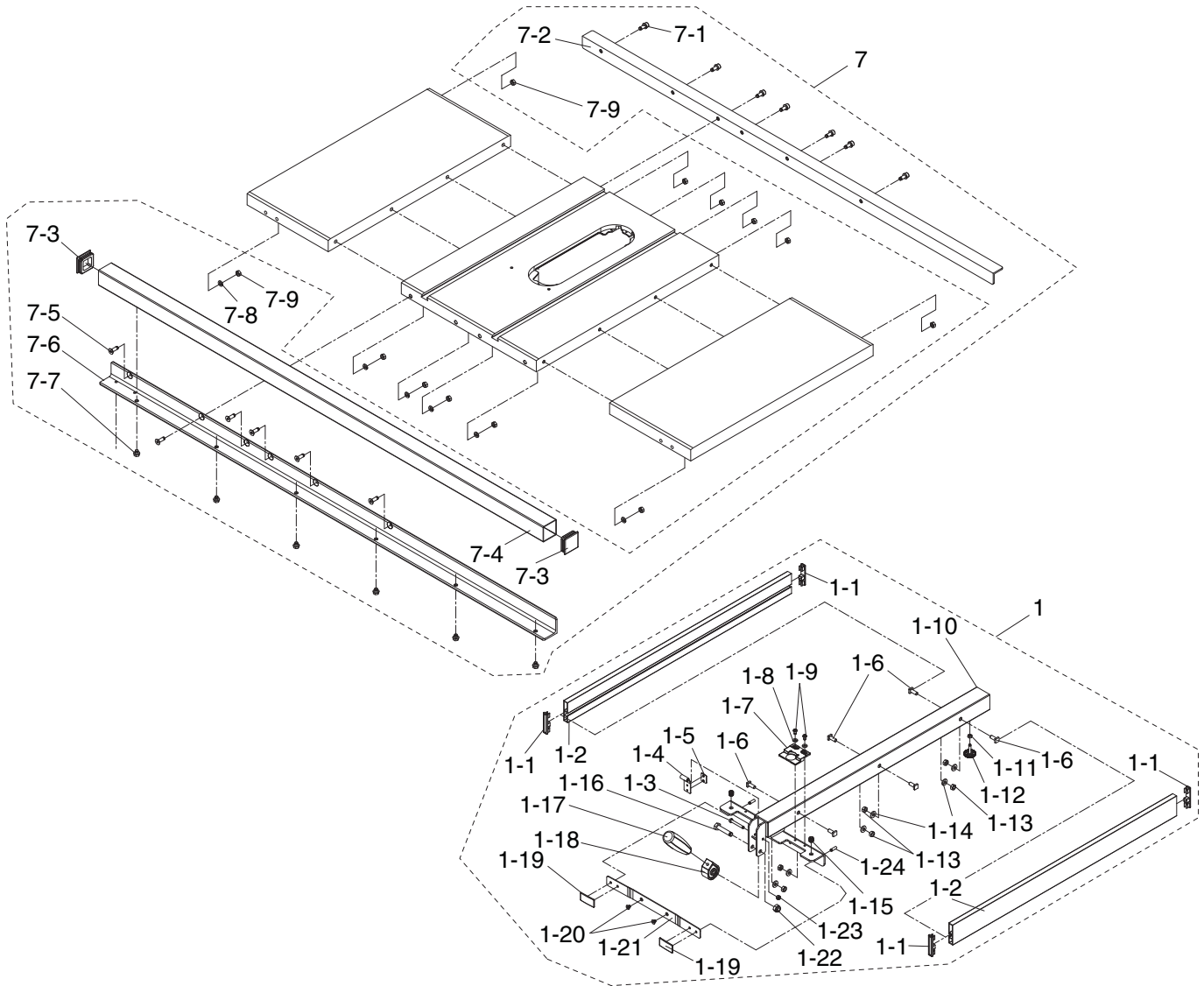

REF	PART #	DESCRIPTION
1	P0661001	FENCE ASSEMBLY
1-1	P0661001-1	PLATE CAP
1-2	P0661001-2	PLATE
1-3	PB71M	HEX BOLT M6-1 X 45
1-4	P0661001-4	CLAMPING BRACKET
1-5	P0661001-5	PLATE
1-6	P0661001-6	SPECIAL SCREW
1-7	P0661001-7	POINTER
1-8	PW03M	FLAT WASHER 6MM
1-9	PS68M	PHLP HD SCR M6-1 X 10
1-10	P0661001-10	FENCE
1-11	PN01M	HEX NUT M6-1
1-12	P0661001-12	REAR RAIL WHEEL
1-13	PN03M	HEX NUT M8-1.25
1-14	PW01M	FLAT WASHER 8MM
1-15	P0661001-15	PLASTIC SET SCREW
1-16	PB73M	HEX BOLT M10-1.5 X 50
1-17	P0661001-17	FENCE HANDLE

REF	PART #	DESCRIPTION
1-18	P0661001-18	CAM ASSEMBLY
1-19	P0661001-19	PLATE
1-20	PS68M	PHLP HD SCR M6-1 X 10
1-21	P0661001-21	BRACKET
1-22	PLN05M	LOCK NUT M10-1.5
1-23	PLN03M	LOCK NUT M6-1
1-24	PSS20M	SET SCREW M8-1.25 X 8
7	P0661007	RAIL
7-1	P0661007-1	SPECIAL CAP SCREW M8-1.25 X 25
7-2	P0661007-2	REAR RAIL
7-3	P0661007-3	END CAP
7-4	P0661007-4	RAIL TUBE
7-5	PFH21M	FLAT HD SCR M8-1.25 X 25
7-6	P0661007-6	FRONT RAIL
7-7	PFB27M	FLANGE BOLT M8-1.25 X 10
7-8	PLW04M	LOCK WASHER 8MM
7-9	PN03M	HEX NUT M8-1.25



Label Placement

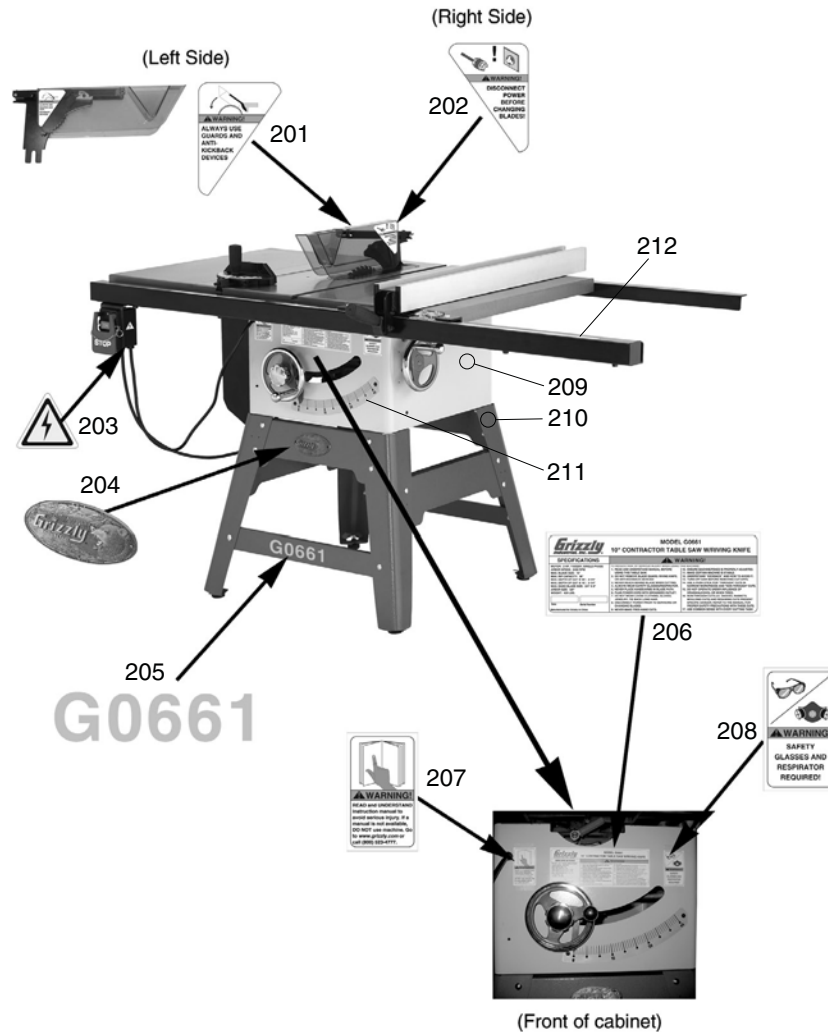

REF	PART #	DESCRIPTION
201	P0661201	USE GUARD LABEL
202	P0661202	DISCONNECT POWER GUARD LABEL
203	PLABEL-14	ELECTRICITY LABEL
204	G9987	GRIZZLY NAMEPLATE
205	P0661205	G0661 MODEL # LABEL
206	P0661206	G0661 MACHINE ID LABEL

REF	PART #	DESCRIPTION
207	PLABEL-12A	READ MANUAL LABEL
208	PLABEL-57	GLASSES RESPIRATOR LABEL
209	PPAINT-11	"PUTTY" TOUCHUP PAINT
210	PPAINT-1	"GRIZZLY GREEN" TOUCHUP PAINT
211	P0661211	BLADE TILT SCALE
212	P0661212	FENCE SCALE

WARNING

Safety labels warn about machine hazards and ways to prevent injury. The owner of this machine **MUST** maintain the original location and readability of the labels on the machine. If any label is removed or becomes unreadable, **REPLACE** that label before using the machine again. Contact Grizzly at (800) 523-4777 or www.grizzly.com to order new labels.





WARRANTY CARD

Name _____

Street _____

City _____ State _____ Zip _____

Phone # _____ Email _____ Invoice # _____

Model # _____ Order # _____ Serial # _____

The following information is given on a voluntary basis. It will be used for marketing purposes to help us develop better products and services. **Of course, all information is strictly confidential.**

1. How did you learn about us?

- Advertisement
- Card Deck
- Friend
- Website
- Catalog
- Other:

2. Which of the following magazines do you subscribe to?

- | | | |
|-------------------------------------------------|----------------------------------------------|-----------------------------------------------|
| <input type="checkbox"/> Cabinet Maker | <input type="checkbox"/> Popular Mechanics | <input type="checkbox"/> Today's Homeowner |
| <input type="checkbox"/> Family Handyman | <input type="checkbox"/> Popular Science | <input type="checkbox"/> Wood |
| <input type="checkbox"/> Hand Loader | <input type="checkbox"/> Popular Woodworking | <input type="checkbox"/> Wooden Boat |
| <input type="checkbox"/> Handy | <input type="checkbox"/> Practical Homeowner | <input type="checkbox"/> Woodshop News |
| <input type="checkbox"/> Home Shop Machinist | <input type="checkbox"/> Precision Shooter | <input type="checkbox"/> Woodsmith |
| <input type="checkbox"/> Journal of Light Cont. | <input type="checkbox"/> Projects in Metal | <input type="checkbox"/> Woodwork |
| <input type="checkbox"/> Live Steam | <input type="checkbox"/> RC Modeler | <input type="checkbox"/> Woodworker West |
| <input type="checkbox"/> Model Airplane News | <input type="checkbox"/> Rifle | <input type="checkbox"/> Woodworker's Journal |
| <input type="checkbox"/> Modeltec | <input type="checkbox"/> Shop Notes | <input type="checkbox"/> Other: |
| <input type="checkbox"/> Old House Journal | <input type="checkbox"/> Shotgun News | |

3. What is your annual household income?

- \$20,000-\$29,000
- \$30,000-\$39,000
- \$40,000-\$49,000
- \$50,000-\$59,000
- \$60,000-\$69,000
- \$70,000+

4. What is your age group?

- 20-29
- 30-39
- 40-49
- 50-59
- 60-69
- 70+

5. How long have you been a woodworker/metalworker?

- 0-2 Years
- 2-8 Years
- 8-20 Years
- 20+ Years

6. How many of your machines or tools are Grizzly?

- 0-2
- 3-5
- 6-9
- 10+

7. Do you think your machine represents a good value? Yes No

8. Would you recommend Grizzly Industrial to a friend? Yes No

9. Would you allow us to use your name as a reference for Grizzly customers in your area?
Note: We never use names more than 3 times. Yes No

10. Comments: _____

CUT ALONG DOTTED LINE

FOLD ALONG DOTTED LINE



Place
Stamp
Here



GRIZZLY INDUSTRIAL, INC.
P.O. BOX 2069
BELLINGHAM, WA 98227-2069



FOLD ALONG DOTTED LINE

Send a Grizzly Catalog to a friend:

Name _____
Street _____
City _____ State _____ Zip _____

TAPE ALONG EDGES--PLEASE DO NOT STAPLE

WARRANTY AND RETURNS

Grizzly Industrial, Inc. warrants every product it sells for a period of **1 year** to the original purchaser from the date of purchase. This warranty does not apply to defects due directly or indirectly to misuse, abuse, negligence, accidents, repairs or alterations or lack of maintenance. This is Grizzly's sole written warranty and any and all warranties that may be implied by law, including any merchantability or fitness, for any particular purpose, are hereby limited to the duration of this written warranty. We do not warrant or represent that the merchandise complies with the provisions of any law or acts unless the manufacturer so warrants. In no event shall Grizzly's liability under this warranty exceed the purchase price paid for the product and any legal actions brought against Grizzly shall be tried in the State of Washington, County of Whatcom.

We shall in no event be liable for death, injuries to persons or property or for incidental, contingent, special, or consequential damages arising from the use of our products.

To take advantage of this warranty, contact us by mail or phone and give us all the details. We will then issue you a "Return Number," which must be clearly posted on the outside as well as the inside of the carton. We will not accept any item back without this number. Proof of purchase must accompany the merchandise.

The manufacturers reserve the right to change specifications at any time because they constantly strive to achieve better quality equipment. We make every effort to ensure that our products meet high quality and durability standards and we hope you never need to use this warranty.

Please feel free to write or call us if you have any questions about the machine or the manual.

Thank you again for your business and continued support. We hope to serve you again soon.

grizzly.com

TOOL WEBSITE

Buy Direct and Save with Grizzly® – Trusted, Proven and a Great Value!

*Visit Our Website Today And Discover
Why Grizzly® Is The Industry Leader!*

- SECURE ORDERING
- ORDERS SHIPPED WITHIN 24 HOURS
- E-MAIL RESPONSE WITHIN ONE HOUR

-OR-

Call Today For A **FREE**
Full Color Catalog

1-800-523-4777

